

Option Table

Part Number	PFM / Force PWM for Light Load Operation	
	PFM	Force PWM
AOZ2253EQI-30	V	
AOZ2253EQI-31		V

Recommended Start-up Sequence

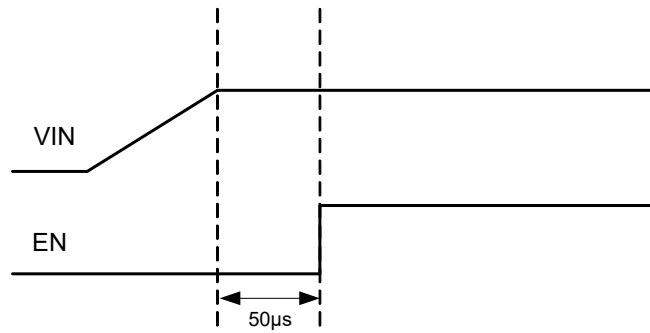

Ordering Information

Part Number	Ambient Temperature Range	Package	Environmental
AOZ2253EQI-30	-40°C to +85°C	22-Pin 4mm x 4mm QFN	Green Product



AOS Green Products use reduced levels of Halogens, and are also RoHS compliant. Please visit www.aosmd.com/media/AOSGreenPolicy.pdf for additional information.

Pin Configuration

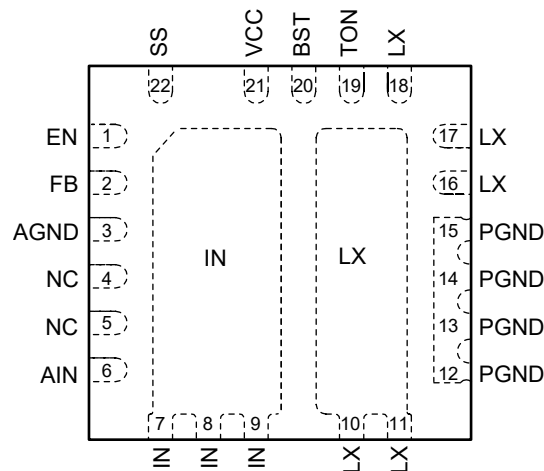

22-Pin 4mm x 4mm QFN
(Top View)

Pin Description

Pin Number	Pin Name	Pin Function
1	EN	Enable Input. The AOZ2253EQI-30 is enabled when EN is pulled high. The device shuts down when EN is pulled low.
2	FB	Feedback Input. Adjust the output voltage with a resistive voltage-divider between the regulator's output and AGND.
3	AGND	Analog Ground.
6	AIN	Supply to internal analog function. AIN pin must be connected to IN pins. For noisy operation, it's better to have a RC filter from IN to AIN for better noise immunity.
7, 8, 9	IN	Supply Input. IN is the regulator input. All IN pins must be connected together.
10, 11, 16, 17, 18	LX	Switching Node.
12, 13, 14, 15	PGND	Power Ground.
19	TON	On-Time Setting Input. Connect a resistor between VIN and TON to set the on time
20	BST	Bootstrap Capacitor Connection. The AOZ2253EQI-30 includes an internal bootstrap diode. Connect an external capacitor between BST and LX as shown in Typical Application diagram.
21	VCC	Supply Input for Analog Functions. Bypass VCC to AGND with a 4.7µF~10µF ceramic capacitor. Place the capacitor close to VCC pin.
22	SS	Soft-Start Time Setting Pin. Connect a capacitor between SS and AGND to set the soft-start time.

Absolute Maximum Ratings

Exceeding the Absolute Maximum Ratings may damage the device.

Parameter	Rating
IN, TON to AGND	-0.3V to 30V
LX to AGND ⁽¹⁾	-0.3V to 30V
BST to AGND	-0.3V to 36V
SS, FB, EN, VCC to AGND	-0.3V to 6V
PGND to AGND	-0.3V to +0.3V
Junction Temperature (T _J)	+150°C
Storage Temperature (T _S)	-65°C to +150°C
ESD Rating ⁽²⁾	2kV

Notes:

- LX to PGND Transient (t<20ns) ----- -7V to V_{IN}+7V.
- Devices are inherently ESD sensitive, handling precautions are required. Human body model rating: 1.5kΩ in series with 100pF.

Maximum Operating Ratings

The device is not guaranteed to operate beyond the Maximum Operating ratings.

Parameter	Rating
Supply Voltage (V _{IN})	6.5V to 28V
Output Voltage Range	0.8V to 0.85*V _{IN}
Ambient Temperature (T _A)	-40°C to +85°C
Package Thermal Resistance (θ _{JA}) (θ _{JC})	32°C/W 4°C/W

Electrical Characteristics

T_A = 25°C, V_{IN}=12V, EN = 5V, unless otherwise specified. Specifications in **BOLD** indicate a temperature range of -40°C to +85°C.

Symbol	Parameter	Conditions	Min.	Typ.	Max	Units
V _{IN}	IN Supply Voltage		6.5		28	V
V _{UVLO}	Under-Voltage Lockout Threshold	V _{CC} rising V _{CC} falling	3.2	4.0 3.7	4.4	V
I _q	Quiescent Supply Current of V _{CC}	I _{OUT} = 0, V _{EN} > 2V, PFM		0.16		mA
I _{OFF}	Shutdown Supply Current	V _{EN} = 0V		15		μA
V _{FB}	Feedback Voltage	T _A = 25°C T _A = 0°C to 85°C	0.792 0.788	0.800 0.800	0.808 0.812	V
	Load Regulation			0.5		%
	Line Regulation			1		%
I _{FB}	FB Input Bias Current				200	nA
Enable						
V _{EN}	EN Input Threshold	Off threshold On threshold	1.6		0.5	V
V _{EN_HYS}	EN Input Hysteresis			100		mV
Modulator						
T _{ON_MIN}	Minimum On Time			60		ns
T _{ON_MAX}	Maximum On Time			2.6		μs
T _{OFF_MIN}	Minimum Off Time			300		ns
Soft-Start						
I _{SS_OUT}	SS Source Current	V _{SS} = 0 C _{SS} = 0.001μF to 0.1μF	7	11	15	μA
Under Voltage and Over Voltage Protection						
V _{PL}	Under Voltage Threshold	FB falling		70		%
T _{PL}	Under Voltage Delay Time			32		μs
V _{PH}	Over Voltage Threshold	FB rising		120		%
Power Stage Output						

