

## General Description

The AOZ5039QI is a high efficiency synchronous buck power stage module consisting of two asymmetrical MOSFETs and an integrated driver. The MOSFETs are individually optimized for operation in the synchronous buck configuration. The high side MOSFET is optimized to achieve low capacitance and gate charge for fast switching with low duty cycle operation. The low side MOSFET has ultra low ON resistance to minimize conduction loss. The compact 5mm x 5mm QFN package is optimally chosen and designed to minimize parasitic inductance for minimal EMI signature.

The AOZ5039QI is intended for use with TTL and Tri-state compatibility by using both the PWM and/or FCCM inputs for accurate control of the power MOSFETs.

A number of features are provided making the AOZ5039QI a highly versatile power module: The bootstrap diode is integrated in the driver. The low side MOSFET can be driven into diode emulation mode to provide asynchronous operation when required. The pin-out is optimized for low inductance routing of the converter, keeping the parasitics and their effects to a minimum.

## Features

- 4.5V to 25V power supply range
- 4.5V to 5.5V driver supply range
- 40A continuous output current
- Up to 50A peak output current
- Integrated bootstrap schottky diode
- Up to 2MHz switching operation
- Tri-state PWM input compatible
- Under-Voltage LockOut protection
- Single FCCM pin control for Shutdown / Diode
- Emulation / CCM operation
- Standard 5mm x 5mm QFN-31L package

## Applications

- Servers
- Notebook computers
- VRMs for motherboards
- Point of load DC/DC converters
- Memory and graphic cards
- Video gaming console



## Typical Application Circuit

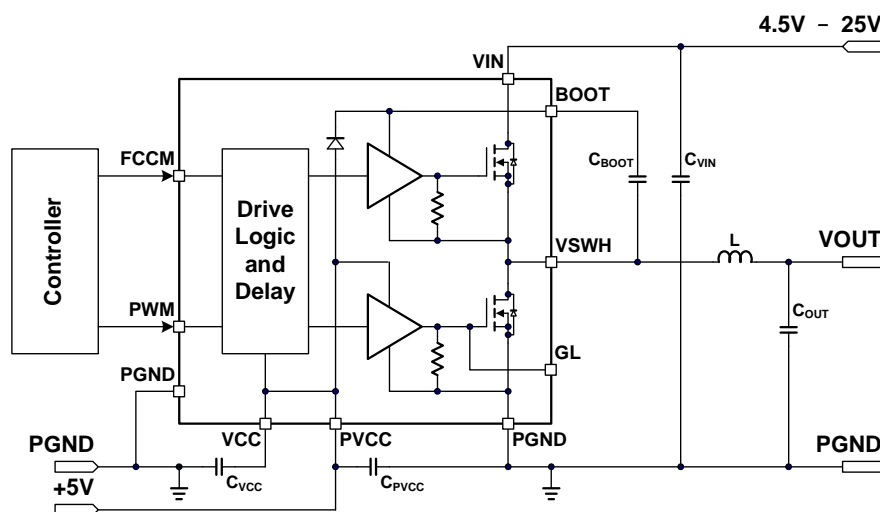

### Ordering Information

Part Number	Ambient Temperature Range	Package	Environmental
AOZ5039QI	-40°C to +85°C	QFN5X5_31L	RoHS



AOS Green Products use reduced levels of Halogens, and are also RoHS compliant. Please visit [www.aosmd.com/media/AOSGreenPolicy.pdf](http://www.aosmd.com/media/AOSGreenPolicy.pdf) for additional information.

### Pin Configuration

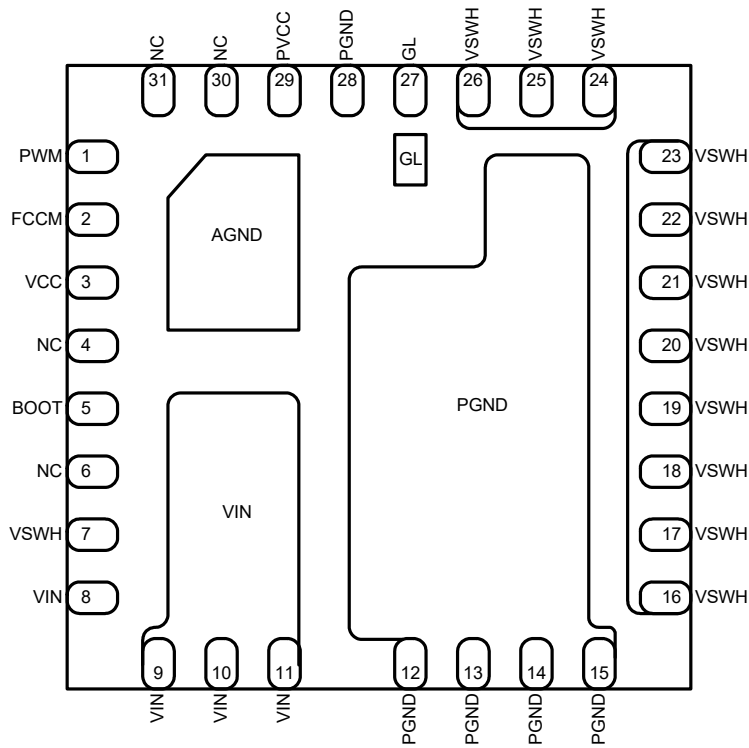

**QFN5x5\_31L  
(Top View)**

## Pin Description

Pin Number	Pin Name	Pin Function
1	PWM	PWM input signal from the controller IC. This input is compatible with 5V and Tri-State logic level Low Side.
2	FCCM	Continuous conduction mode of operation is allowed when FCCM = High. Discontinuous mode is allowed and diode emulation mode is active when FCCM = Low. High impedance on the input of FCCM will shutdown both high side and low side MOSFETs.
3	VCC	Driver low voltage input pin.
4, 6, 30, 31	NC	No connect.
5	BOOT	High side MOSFET gate driver supply rail. Connect a 100nF ceramic capacitor between BOOT and VSWH (Pin 7).
7	VSWH	Switching node connected to the source of high side MOSFET and the drain of low side MOSFET. This pin is dedicated for bootstrap capacitor connection to BOOT pin.
8, 9, 10, 11	VIN	Power stage high voltage input pin.
12, 13, 14, 15	PGND	Power ground pin for power stage.
16, 17, 18, 19, 20, 21, 22, 23, 24, 25, 26	VSWH	Switching node connected to the source of high side MOSFET and the drain of low side MOSFET. These pins are being used for zero cross detect, bootstrap UVLO and Anti-overlap control.
27	GL	Low side MOSFET gate connection. This is for test use only.
28	PGND	Power ground pin for low side MOSFET gate driver.
29	PVCC	Low side MOSFET gate driver supply rail.

## Functional Block Diagram

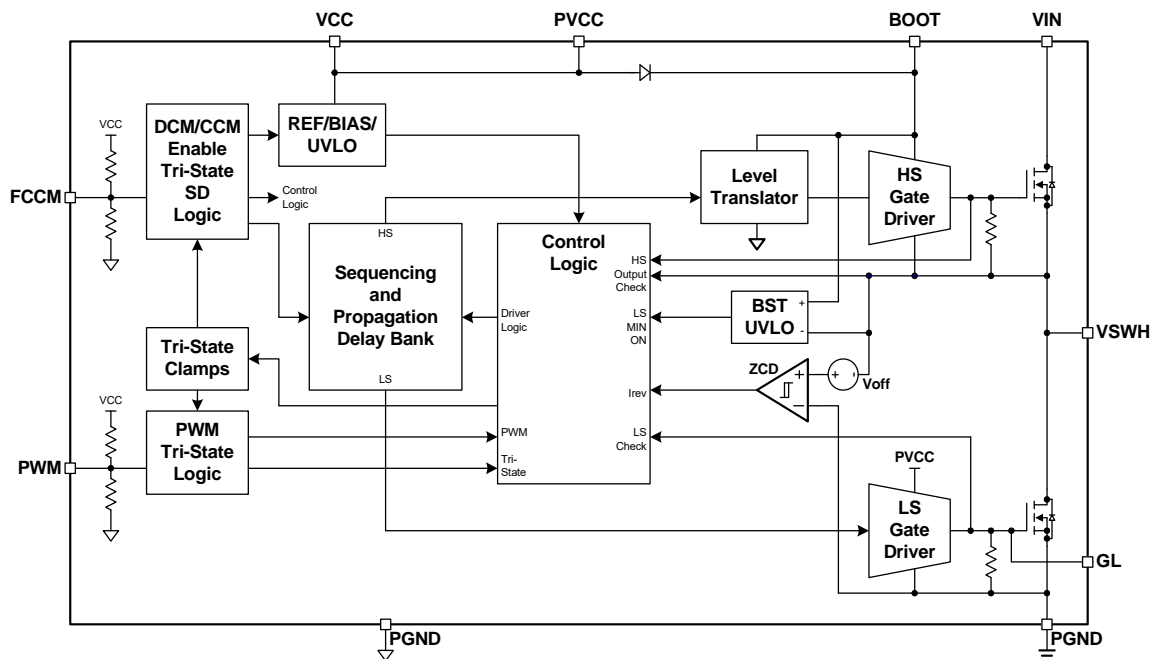

## Absolute Maximum Ratings

Exceeding the Absolute Maximum ratings may damage the device.

Parameter	Rating
Low Voltage Supply (VCC, PVCC)	-0.3V to 7V
High Voltage Supply (VIN)	-0.3V to 30V
Control Inputs (PWM, FCCM)	-0.3V to (VCC+0.3V)
Bootstrap Voltage DC (BOOT-PGND)	-0.3V to 33V
Bootstrap Voltage DC (BOOT-VSWH)	-0.3V to 7V
BOOT Voltage Transient <sup>(1)</sup> (BOOT-VSWH)	-0.3V to 9V
Switch Node Voltage DC (VSWH)	-0.3V to 30V
Switch Node Voltage Transient <sup>(1)</sup> (VSWH)	-8V to 38V
Low Side Gate Voltage DC (GL)	(PGND-0.3V) to (PVCC+0.3V)
Low Side Gate Voltage Transient <sup>(2)</sup> (GL)	(PGND-2.5V) to (PVCC+0.3V)
Storage Temperature (T <sub>S</sub> )	-65°C to +150°C
Max Junction Temperature (T <sub>J</sub> )	150°C
ESD Rating <sup>(3)</sup>	2kV

### Notes:

1. Peak voltages can be applied for 10ns per switching cycle.
2. Peak voltages can be applied for 20ns per switching cycle.
3. Devices are inherently ESD sensitive, handling precautions are required. Human body model rating: 1.5kΩ in series with 100pF.

## Recommended Operating Conditions

The device is not guaranteed to operate beyond the Maximum Recommended Operating Conditions.

Parameter	Rating
High Voltage Supply (VIN)	4.5V to 25V
Low Voltage Supply {PVCC, (BOOT-VSWH)}	4.5V to 5.5V
Control Inputs (PWM, FCCM)	0V to (VCC-0.3V)
Operating Frequency	200kHz to 2MHz

## Electrical Characteristics<sup>(4)</sup>

$T_A = 25^\circ\text{C}$ ,  $V_{IN} = 12\text{V}$ ,  $P_{VCC} = V_{CC} = 5\text{V}$  unless otherwise specified.

Symbol	Parameter	Conditions	Min.	Typ.	Max.	Units
$V_{IN}$	Power Stage Power Supply		4.5		25	V
$P_{VCC}$	Driver Power Supply	$PVCC = 5\text{V}$	4.5		5.5	V
$R_{\theta JC}^{(5)}$	Thermal Resistance	PCB Temp = $100^\circ\text{C}$		2.5		$^\circ\text{C} / \text{W}$
$R_{\theta JA}^{(5)}$		AOS Demo Board		13.8		$^\circ\text{C} / \text{W}$
<b>INPUT SUPPLY AND UVLO</b>						
$V_{CC}$	Under-Voltage Lockout	VCC Rising		3.5	3.9	V
		VCC Falling		3.1		V
$V_{CC\_HYST}$	Under-Voltage Lockout Hysteresis			500		mV
$I_{VCC\_SD}$	Shutdown Bias Supply Current	FCCM = Floating, PWM = Floating		3		$\mu\text{A}$
$I_{PVCC}$	Control Circuit Bias Current	FCCM = 5V, PWM = Floating		85		$\mu\text{A}$
		FCCM = 0V, PWM = Floating		140		$\mu\text{A}$
<b>PWM INPUT</b>						
$V_{PWMH}$	PWM Input High Threshold	$V_{PWM}$ Rising, $PVCC = 5\text{V}$			4.1	V
$V_{PWML}$	PWM Input Low Threshold	$V_{PWM}$ Falling, $PVCC = 5\text{V}$	0.7			V
$I_{PWM}$	PWM Pin Input Current	Source, PWM = 0V to 5V		+250		$\mu\text{A}$
		Sink, PWM = 5V to 0V		-250		$\mu\text{A}$
$V_{TRI}$	PWM Input Tri-State Threshold Window	PWM = High Impedance	1.65		3.50	V
<b>FCCM INPUT</b>						
$V_{FCCMH}$	FCCM Enable Threshold	FCCM Rising, $PVCC = 5\text{V}$			3.8	V
$V_{FCCML}$	FCCM Disable Threshold	FCCM Falling, $PVCC = 5\text{V}$	1.2			V
$I_{FCCM}$	FCCM Pin Input Current	Source, FCCM = 5V		+50		$\mu\text{A}$
		Sink, FCCM = 0V		-50		$\mu\text{A}$
$t_{PS4\_EXIT}$	PS4 Exit Latency	$PVCC = 5\text{V}$			15	$\mu\text{s}$
<b>GATE DRIVER TIMING</b>						
$t_{PDLU}$	PWM Falling to GH <sup>(6)</sup> Turn-Off	PWM 10%, GH 90%		18		ns
$t_{PDLL}$	PWM Raising to GL Turn-Off	PWM 90%, GL 90%		25		ns
$t_{PDHU}$	GL Falling to GH Rising Deadtime	GL 10%, GH 10%		20		ns
$t_{PDHL}$	GH/VSWH Falling to GL Rising Deadtime	GH-VSWH @ 1V, GL 10%		20		ns
$t_{TSSHD}$	Tri-State Shutdown Delay	Tri-state to GH Falling, Tri-state to GL Falling		135		ns
$t_{PTS}$	Tri-State Propagation Delay	Tri-state exit		35		ns
$t_{LGMIN}$	Low-Side Minimum On-Time	FCCM = 0V, DCM mode		600		ns

### Notes:

- All voltages are specified with respect to the corresponding PGND pin.
- Characterization value. Not tested in production.
- GH is the internal gate pin of high-side MOSFET.

## Timing Diagram

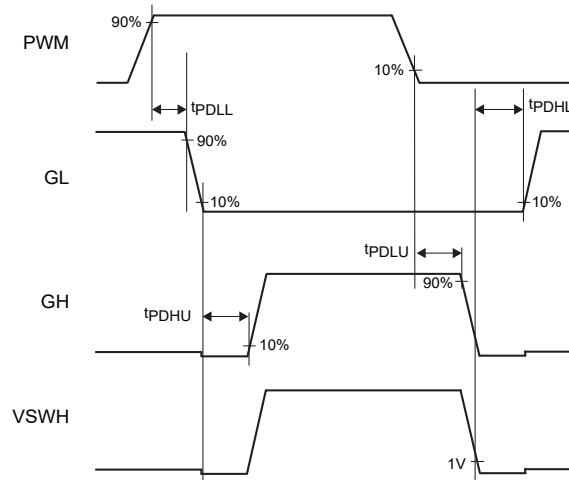

Figure 1. PWM Logic Input Timing Diagram

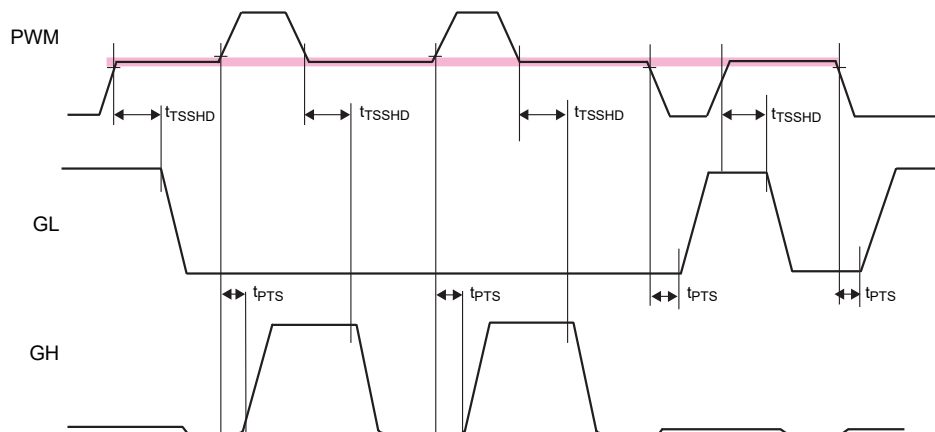

Figure 2. Tri-State Input Logic Timing Diagram

## Typical Performance Characteristics

$T_A = 25^\circ\text{C}$ ,  $V_{IN} = 19\text{V}$ ,  $PVCC = VCC = 5\text{V}$ , unless otherwise specified.

Figure 3. Efficiency vs. Load Current

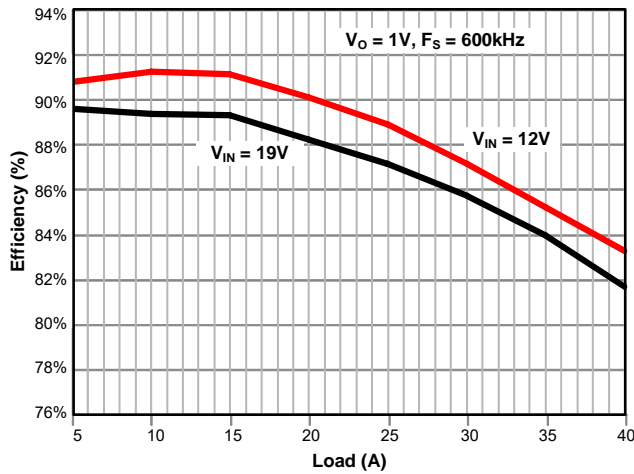

Figure 4. Module Loss Vs. Load Current

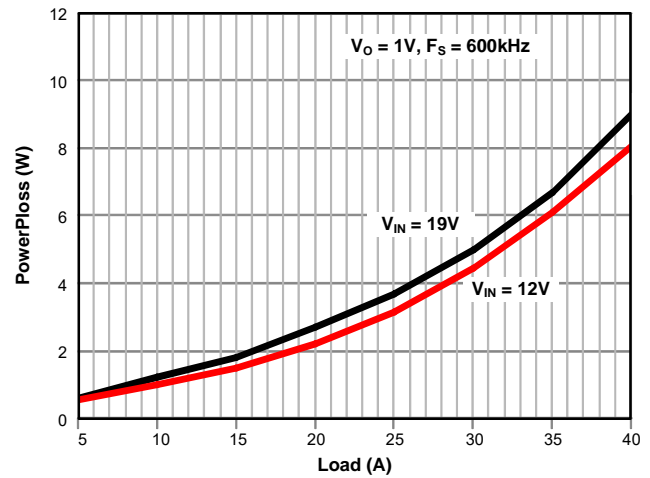

Figure 5. Quiescent Current vs. Temperature

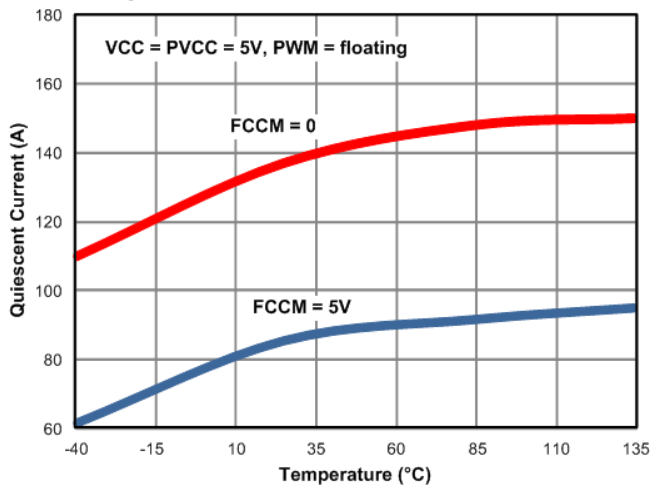

Figure 6. Shutdown Current vs. Temperature

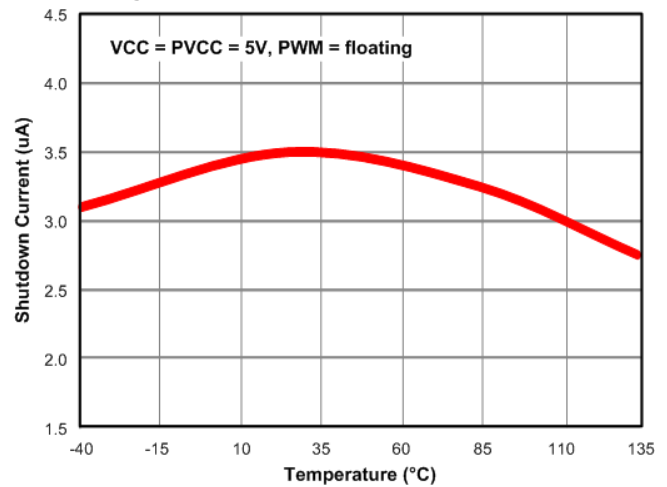

Figure 7. UVLO Threshold vs. Temperature

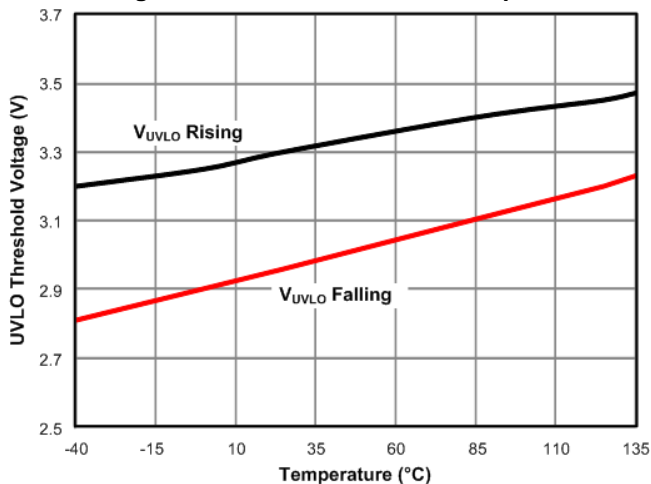
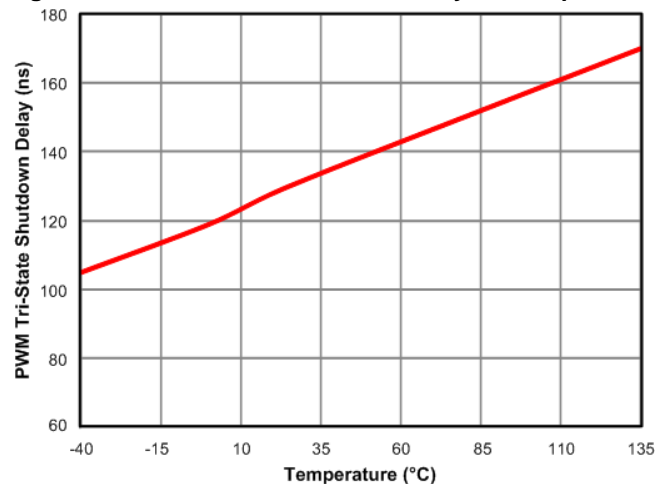

Figure 8. PWM Tri-State Shutdown Delay vs. Temperature



Typical Performance Characteristics (Continued)

Figure 9. PWM Input Threshold vs. Temperature

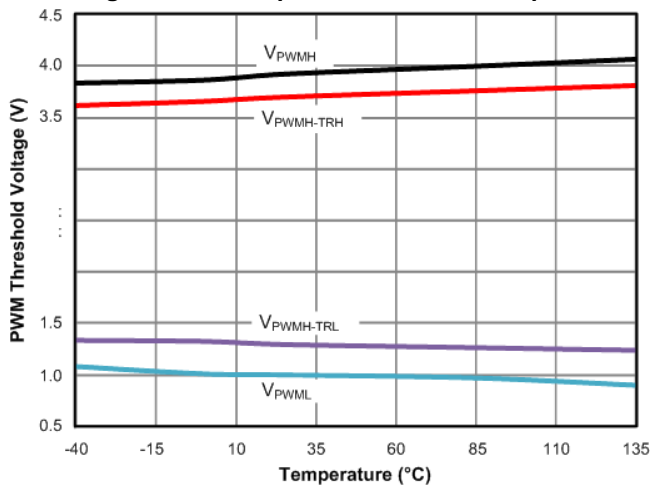

Figure 10. FCCM Input Threshold vs. Temperature

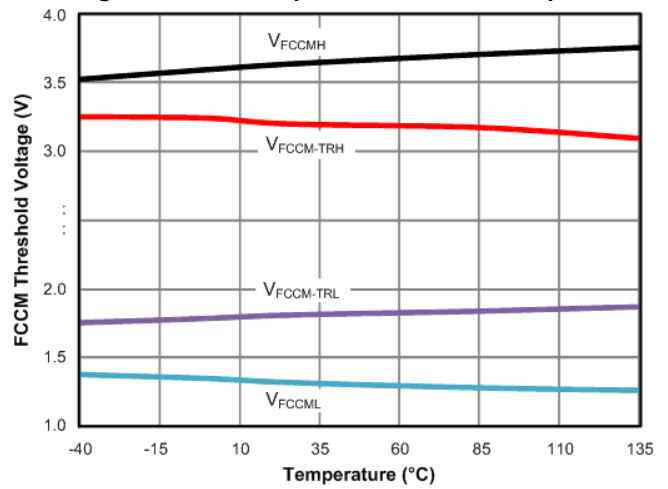

Figure 11. PS4 Exit Latency vs. Temperature

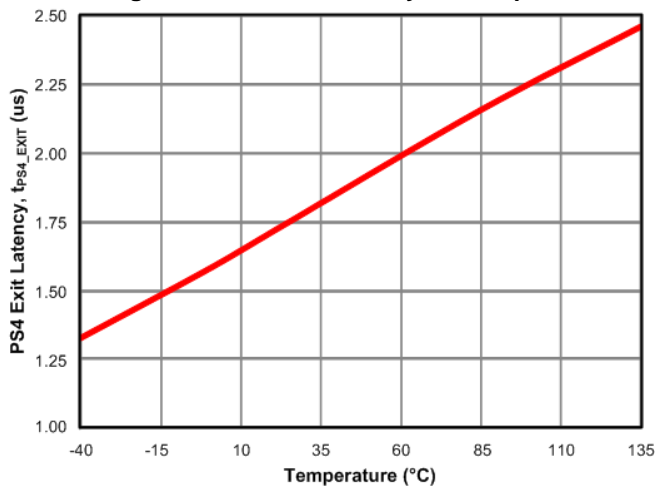
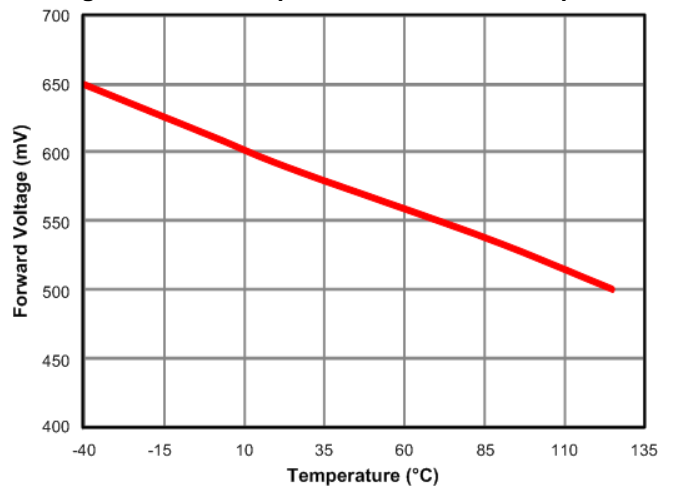

Figure 12. Bootstrap Diode Forward vs. Temperature





## Application Information

AOZ5039QI is a fully integrated power module designed to work over an input voltage range of 4.5V to 25V with a separate 5V supply for gate drive and internal control circuits. A number of desirable features makes AOZ5039QI a highly versatile power module. The MOSFETs are individually optimized for efficient operation on either high side or low side switches in a low duty cycle synchronous buck converter. A high current driver is also integrated in the package which minimizes the gate drive loop and results in extremely fast switching. The modules are fully compatible with Intel DrMOS specification IMVP8 (VRM13) in form fit and function.

### Powering the Module and the Gate Drives

An external supply PVCC of 5V is required for driving the MOSFETs. The MOSFETs are designed with low gate thresholds so that lower drive voltage can be used to reduce the switching and drive losses without compromising the conduction losses. The integrated gate driver is capable of supplying large peak current into the low side MOSFET to achieve extremely fast switching. A ceramic bypass capacitor 1 $\mu$ F or higher is recommended from PVCC to PGND. For effective filtering it is strongly recommended to directly connect this capacitor to PGND (pin 28).

The boost supply for driving the high side MOSFET is generated by connecting a small capacitor between BOOT pin and the switching node VSWH. It is recommended that this capacitor Cboot be connected as close as possible to the device across pins 5 and 7. Boost diode is integrated into the package. A resistor in series with Cboot can be optionally used by designers to slow down the turn on speed of the high side MOSFET. Typically values between 1 $\Omega$  to 5 $\Omega$  is a compromise between the need to keep both the switching time and VSWH node spikes as low as possible.

### Undervoltage Lockout

In a UVLO event, both GH and GL outputs are actively held low until adequate gate supply becomes available. The under-voltage lockout is set to 3.4V with a 500mV hysteresis. The AOZ5039QI must be powered up before the PWM input is applied.

Since the PWM control signals are provided typically from an external controller or a digital processor, extra care must be taken during start up. It should be ensured that PWM signal goes through a proper soft start sequence to minimize in-rush current through the converter during start up. Powering the module with a full duty cycle PWM signal may lead to a number of undesirable consequences as explained below. In general it should be noted that AOZ5039QI is a combination of two

MOSFETs with an IMVP8 compliant driver, all of which are optimized for switching at the highest efficiency. Other than UVLO and thermal protection, it does not have any monitoring or protection functions built in. The PWM controller should be designed in to perform these functions under all possible operating and transient conditions.

### Input Voltage VIN

AOZ5039QI is rated to operate over a wide input range of 4.5V to 25V. As with any other synchronous buck converter, large pulse currents at high frequency and extremely high di/dt rates will be drawn by the module during normal operation. It is strongly recommended to bypass the input supply very close to package leads with X7R or X5R quality surface mount ceramic capacitors.

The high side MOSFET in AOZ5039QI is optimized for fast switching with low duty ratios. It has ultra low gate charges which have been achieved as a trade off with higher RDS(ON) value. When the module is operated at low VIN, the duty ratio will be higher and conduction losses in the HS FET will also be correspondingly higher. This will be compensated to some extent by reduced switching losses. The total power loss in the module may appear to be low even though in reality the HS MOSFET losses may be disproportionately high. Since the two MOSFETs have their own exposed pads and PCB copper areas for heat dissipation, the HS MOSFET may be much hotter than the LS MOSFET. It is recommended that worst case junction temperature be measured and ensured to be within safe limits when the module is operated with high duty ratios.

### PWM Input

AOZ5039QI is offered in two versions which can be interfaced with PWM logic compatible with either 5V (TTL). Refer to Fig. 1 for the timing and propagation delays between the PWM input and the gate drives.

The PWM is also a tri-state compatible input. When the input is high impedance or unconnected both the gate drives will be off and the gates are held active low. The PWM Threshold Table in Table 1 lists the thresholds for high and low level transitions as well as tri-state operation. As shown in Fig. 2, there is a hold off delay between the corresponding gate drive is pulled low. This delay is typically 175ns and intended to prevent spurious triggering of the tri-state mode which may be caused either by noise induced glitches in the PWM waveform or slow rise and fall times.

**Table 1. PWM Input and Tri-State Thresholds**

Thresholds →	V <sub>PWMH</sub>	V <sub>PWML</sub>	V <sub>TRIH</sub>	V <sub>TRIL</sub>
AOZ5039QI	4.1 V	0.7 V	1.65 V	3.50 V

**Note:** See Figure 2 for propagation delays and tri-state window.

### Diode Mode Emulation of Low Side MOSFET (FCCM)

AOZ5039QI can be operated in the diode emulation or skip mode using the FCCM pin. This is useful if the converter has to operate in asynchronous mode during start up, light load or under pre bias conditions. If FCCM is taken high, the controller will use the PWM signal as reference and generate both the high and low side complementary gate drive outputs with the minimal delays necessary to avoid cross conduction. When the pin is taken low the HS MOSFET drive is not affected but diode emulation mode is activated for the LS MOSFET. See Table 2 for a comprehensive view of all logic inputs and corresponding drive conditions. A high impedance state at the FCCM pin shuts down the AOZ5039QI.

**Table 2. Control Logic Truth Table**

FCCM	PWM	GH	GL
L	L	L	L
L	H	H	L
H	L	L	H
H	H	H	L
L	Tri-State	L	L
H	Tri-State	L	L
Tri-State	X	L	L

**Note:** Diode emulation mode is activated when FCCM pin is held low.

### Gate Drives

AOZ5039QI has an internal high current high speed driver that generates the floating gate drive for the HS MOSFET and a complementary drive for the LS MOSFET.

Propagation delays between transitions of the PWM waveform and corresponding gate drives are kept to the minimum. An internal shoot through protection scheme ensures that neither MOSFET turns on while the other one is still conducting, thereby preventing shoot through condition of the input current. When the PWM signal makes a transition from H to L or L to H, the corresponding gate drive GH or GL begins to turn off. The adaptive timing circuit monitors the falling edge of the gate voltage and when the level goes below 1V, the complementary gate driver is turned on. The dead time between the two switches is minimized, at the same time

preventing cross conduction across the input bus. The adaptive circuit also monitors the switching node V<sub>SWH</sub> and ensures that transition from one MOSFET to another always takes place without cross conduction, even under transient and abnormal conditions of operation.

The gate pin GL is brought out on pin 27 for diagnostic purpose. However this connection is not made directly to MOSFET gate pad and its voltage measurement may not reflect the actual gate voltage applied inside the package. The gate connection is primarily for functional tests during manufacturing and no connection should be made to it in the applications.

### PCB Layout Guidelines

AOZ5039QI is a high current module rated for operation up to 2MHz. This requires extremely fast switching speeds to keep the switching losses and device temperatures within limits. Having a robust gate driver integrated in the package eliminates driver-to-MOSFET gate pad parasitics of the package or PCB.

While excellent switching speeds are achieved, correspondingly high levels of dv/dt and di/dt will be observed throughout the power train which requires careful attention to PCB layout to minimize voltage spikes and other transients. As with any synchronous buck converter layout, the critical requirement is to minimize the area of the primary switching current loop, formed by the HS MOSFET, LS MOSFET and the input bypass capacitor C<sub>in</sub>. The PCB design is somewhat simplified because of the optimized pin out in AOZ5039QI. The bulk of VIN and PGND pins are located adjacent to each other and the input bypass capacitors should be placed as close as possible to these pins. The area of the secondary switching loop, formed by LS MOSFET, output inductor and output capacitor C<sub>out</sub> is the next critical parameter, this requires second layer or “Inner 1” should always be an uninterrupted ground plane with sufficient vias placed as close as possible to by-pass capacitors soldering pads.

As shown in Fig. 13, the top most layer of the PCB should comprise of uninterrupted copper flooding for the primary AC current loop which runs along the VIN copper plane originating from the bypass capacitors C10, C11 and C12 which are mounted to a large PGND copper plane, also on the top most layer of the PCB. These copper planes also serve as heat dissipating elements as heat flows down to the VIN exposed pad and onto the top layer VIN copper plane which fans out to a wider area moving away from the 5x5 QFN package. Adding vias will only help transfer heat to cooler regions of the PCB

board through the other 3 layers (if 4 layer PCB is used) beneath but serve no purpose to AC activity as all the AC current sees the lowest impedance on the top layer only.

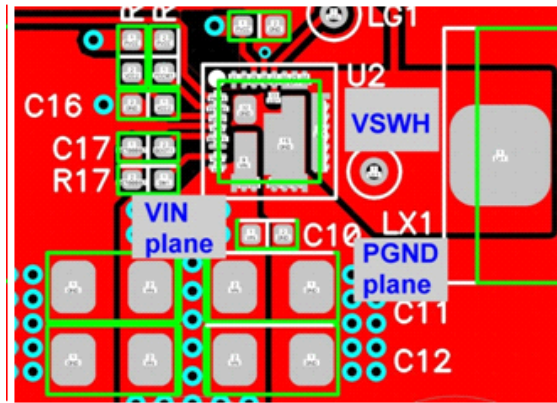

Figure 13. Top layer of demo board, VIN, VSWH and PGND copper planes

Due to the optimized bonding technique used on the AOZ5039QI internal package, the VIN input capacitors are optimally placed for AC current activities on both the primary and complimentary current loops. The return path of the current during the complimentary period flows through a non interrupted PGND copper plane that is symmetrically proportional to the VIN copper plane.

Due to the PGND exposed pad, heat is optimally dissipated by flowing down through the vertically structured lower MOSFET, through the exposed PGND pad and down to the PCB top layer PGND copper plane that also fans outward, moving away from the package. The bottom layer of PBC layout is shown in Fig. 14.

Due to the PGND exposed pad, heat is optimally dissipated simply by flowing down through the vertically structured lower MOSFET, through the exposed PGND pad and down to the PCB top layer PGND copper plane that also fans outward, moving away from the package.

As the primary and secondary (complimentary) AC current loops move through VIN to VSWH and through PGND to VSWH, large positive and negative voltage spike appear at the VSWH terminal which are caused by the large internal di/dts produced through the in package parastics. To minimize the effects of this interference, the VSWH terminal at which the main inductor L1 is mounted to, is sized just so the inductor can physically fit. The goal is to employ the least amount of copper area for this VSWH terminal just enough so the inductor can be securely mounted.

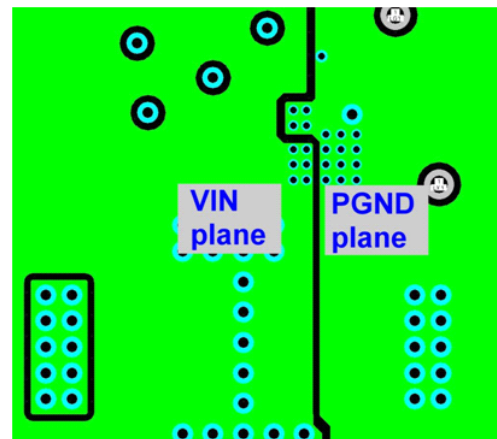
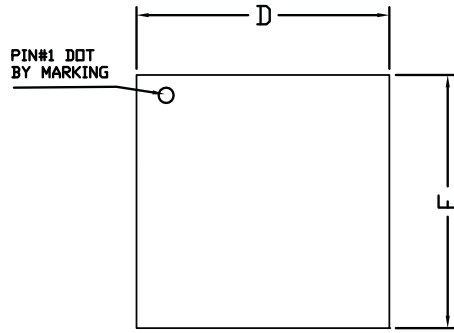
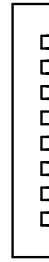

Figure 14. Bottom layer PCB layout. VSWH copper plane voided on descending layers.

Package Dimensions, QFN5x5A\_31L EP3\_S



TOP VIEW



SIDE VIEW

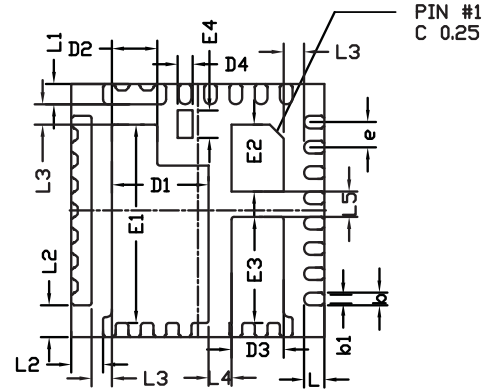

BOTTOM VIEW

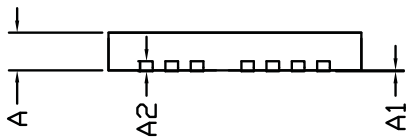

SIDE VIEW

RECOMMENDED LAND PATTERN

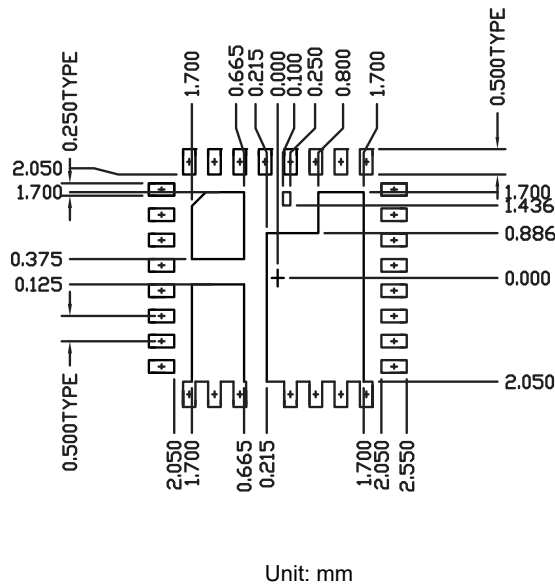

Dimensions in mm      Dimensions in inches

Symbols	Min.	Typ.	Max.	Min.	Typ.	Max.
A	0.700	0.750	0.800	0.028	0.030	0.031
A1	0.000	-	0.050	0.000	-	0.002
A2	0.2REF			0.008REF		
D	4.900	5.000	5.100	0.193	0.197	0.201
E	4.900	5.000	5.100	0.193	0.197	0.201
D1	1.870	1.920	1.970	0.074	0.076	0.078
D2	0.850	0.900	0.950	0.033	0.035	0.037
D3	0.990	1.040	1.090	0.039	0.041	0.043
D4	0.250	0.300	0.350	0.010	0.012	0.014
E1	3.875	3.925	3.975	0.153	0.155	0.156
E2	1.270	1.320	1.370	0.050	0.052	0.054
E3	2.050	2.100	2.150	0.081	0.083	0.085
E4	0.500	0.550	0.600	0.020	0.022	0.024
L	0.350	0.400	0.450	0.014	0.016	0.018
L1	0.350	0.400	0.450	0.014	0.016	0.018
L2	0.575	0.625	0.675	0.023	0.025	0.027
L3	0.350	0.400	0.450	0.014	0.016	0.018
L4	0.400	0.450	0.500	0.016	0.018	0.020
L5	0.450	0.500	0.550	0.018	0.020	0.022
b	0.200	0.250	0.300	0.008	0.010	0.012
b1	0.130	0.180	0.230	0.005	0.007	0.009
e	0.50BSC			0.02BSC		

**Note:**  
Controlling dimension are in millimeters. Converted inch dimensions are not necessarily exact.

### Tape and Reel Dimensions, QFN5x5A\_31L\_EP3\_S

#### Carrier Tape

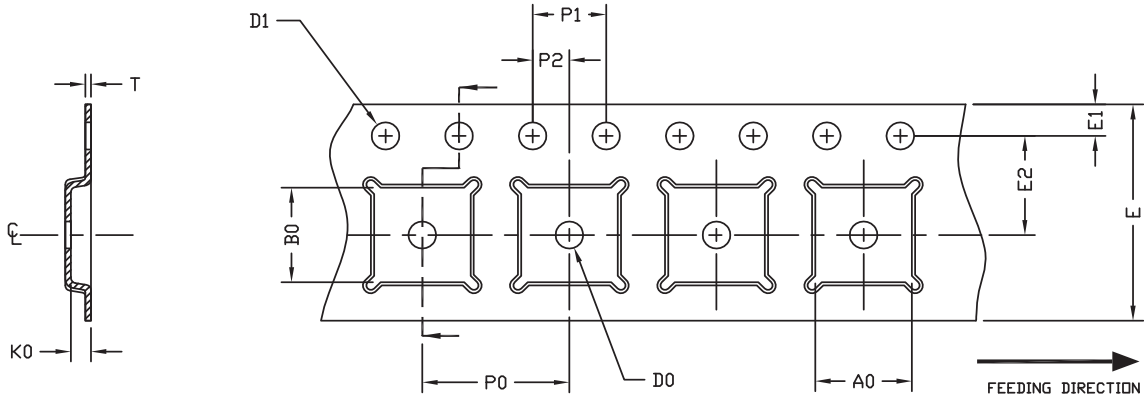

UNIT: MM

PACKAGE	A0	B0	K0	D0	D1	E	E1	E2	P0	P1	P2	T
QFN5x5 (12 mm)	5.25 ±0.10	5.25 ±0.10	1.10 ±0.10	1.50 MIN.	1.50 $+0.1$ $-0.0$	12.0 ±0.3	1.75 ±0.10	5.50 ±0.05	8.00 ±0.10	4.00 ±0.10	2.00 ±0.05	0.30 ±0.05

#### Reel

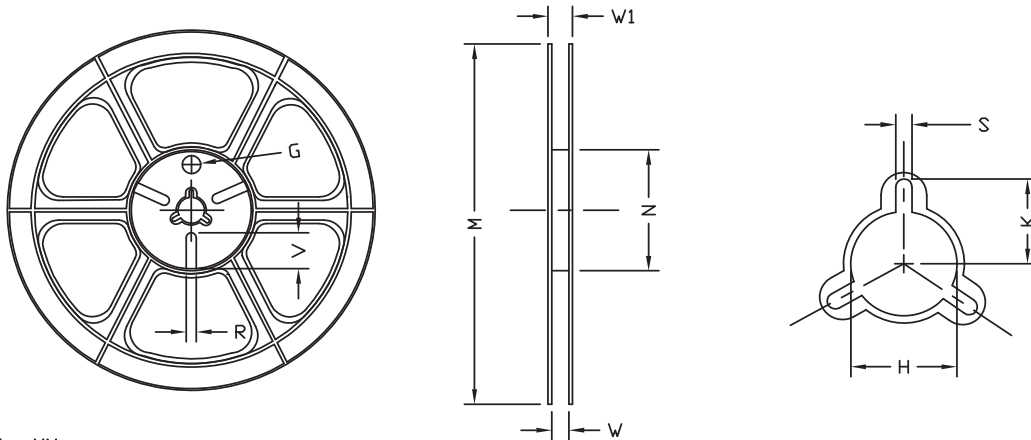

UNIT: MM

TAPE SIZE	REEL SIZE	M	N	W	W1	H	K	S	G	R	V
12 mm	ø330	ø330.0 ±2.0	ø79.0 ±1.0	12.4 $+2.0$ $-0.0$	17.0 $+2.6$ $-1.2$	ø13.0 ±0.5	10.5 ±0.2	2.0 ±0.5	---	---	---

#### Leader/Trailer & Orientation

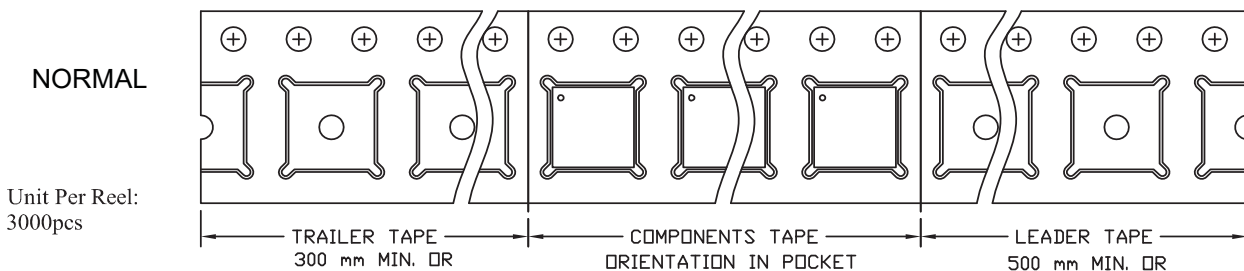

## Part Marking

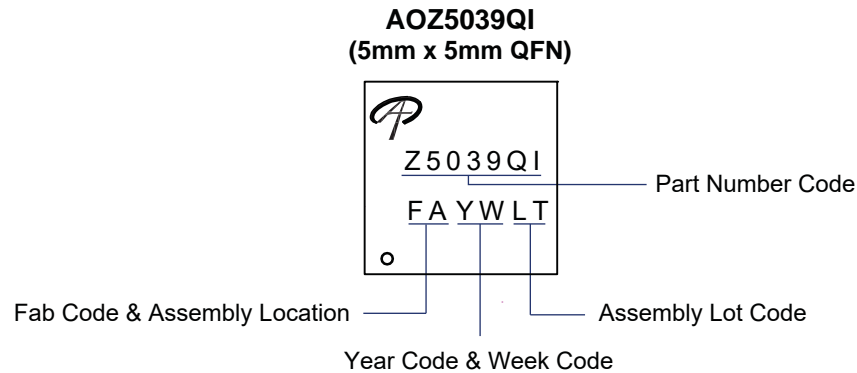

### LEGAL DISCLAIMER

Applications or uses as critical components in life support devices or systems are not authorized. AOS does not assume any liability arising out of such applications or uses of its products. AOS reserves the right to make changes to product specifications without notice. It is the responsibility of the customer to evaluate suitability of the product for their intended application. Customer shall comply with applicable legal requirements, including all applicable export control rules, regulations and limitations.

AOS' products are provided subject to AOS' terms and conditions of sale which are set forth at:  
[http://www.aosmd.com/terms\\_and\\_conditions\\_of\\_sale](http://www.aosmd.com/terms_and_conditions_of_sale)

### LIFE SUPPORT POLICY

ALPHA AND OMEGA SEMICONDUCTOR PRODUCTS ARE NOT AUTHORIZED FOR USE AS CRITICAL COMPONENTS IN LIFE SUPPORT DEVICES OR SYSTEMS.

As used herein:

1. Life support devices or systems are devices or systems which, (a) are intended for surgical implant into the body or (b) support or sustain life, and (c) whose failure to perform when properly used in accordance with instructions for use provided in the labeling, can be reasonably expected to result in a significant injury of the user.

2. A critical component in any component of a life support, device, or system whose failure to perform can be reasonably expected to cause the failure of the life support device or system, or to affect its safety or effectiveness.