

## General Description

The AOZ8251BDI-03 is a one-line bi-directional transient voltage suppressor diode designed to protect voltage sensitive electronics from high transient conditions and ESD.

This device incorporates bi-directional TVS diode in an ultra-small DFN 1006 package. It may be used to meet the ESD immunity requirements of IEC 61000-4-2, Level 4 ( $\pm 15\text{kV}$  air,  $\pm 8\text{kV}$  contact discharge).

The AOZ8251BDI-03 comes in an RoHS compliant DFN 1.0 mm x 0.6 mm package and is rated over a  $-40^{\circ}\text{C}$  to  $+125^{\circ}\text{C}$  ambient temperature range.

The ultra-small 0.62 mm x 0.32 mm x 0.5 mm DFN package makes it ideal for applications where PCB space is a premium. The small size and high ESD protection makes it ideal for protecting voltage sensitive electronics from high transient conditions and ESD.

## Features

- ESD protection for high-speed data lines
  - AOZ8251BDI-03:
    - Exceeds: IEC 61000-4-2 (ESD)  $\pm 20\text{ kV}$  (air),  $\pm 20\text{ kV}$  (contact)
    - Human Body Model (HBM)  $\pm 30\text{ kV}$
    - IEC 61000-4-5 (Lightning) 4 A (8/20  $\mu\text{s}$ )
- Pb-free device

## Applications

- Portable handheld devices
- Keypads, data lines, buttons
- Notebook computers
- Digital cameras
- Portable GPS



## Typical Application

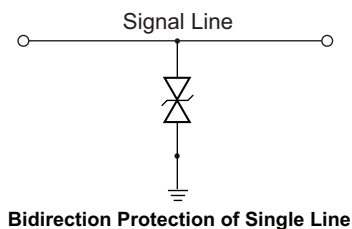

## Pin Configuration



## Ordering Information

| Part Number   | Ambient Temperature Range | Package         | Environmental |
|---------------|---------------------------|-----------------|---------------|
| AOZ8251BDI-03 | -40°C to +125°C           | DFN 0.62 x 0.32 | Green Product |



AOS Green Products use reduced levels of Halogens, and are also RoHS compliant.  
Please visit [www.aosmd.com/web/quality/rohs\\_compliant.jsp](http://www.aosmd.com/web/quality/rohs_compliant.jsp) for additional information.

## Absolute Maximum Ratings

*Exceeding the Absolute Maximum ratings may damage the device.*

| Parameter   | Rating          |
|---|-----------------|
| VP – VN   | 3.3 V           |
| Peak Pulse Current, $t_p = 8/20 \mu s$              | 4 A             |
| Storage Temperature ( $T_S$ )                       | -65°C to +150°C |
| ESD Rating per IEC61000-4-2, Contact <sup>(1)</sup> | ± 20 kV         |
| ESD Rating per IEC61000-4-2, Air <sup>(1)</sup>     | ± 20 kV         |
| ESD Rating per Human Body Model <sup>(2)</sup>      | ± 30 kV         |

### Notes:

- IEC 61000-4-2 discharge with  $C_{Discharge} = 150 \text{ pF}$ ,  $R_{Discharge} = 330 \Omega$ .
- Human Body Discharge per MIL-STD-883, Method 3015  $C_{Discharge} = 100 \text{ pF}$ ,  $R_{Discharge} = 1.5 \text{ k}\Omega$ .

## Maximum Operating Ratings

| Parameter                      | Rating          |
|--------------------------------|-----------------|
| Junction Temperature ( $T_J$ ) | -40°C to +125°C |

## Electrical Characteristics

T<sub>A</sub> = 25°C unless otherwise specified.

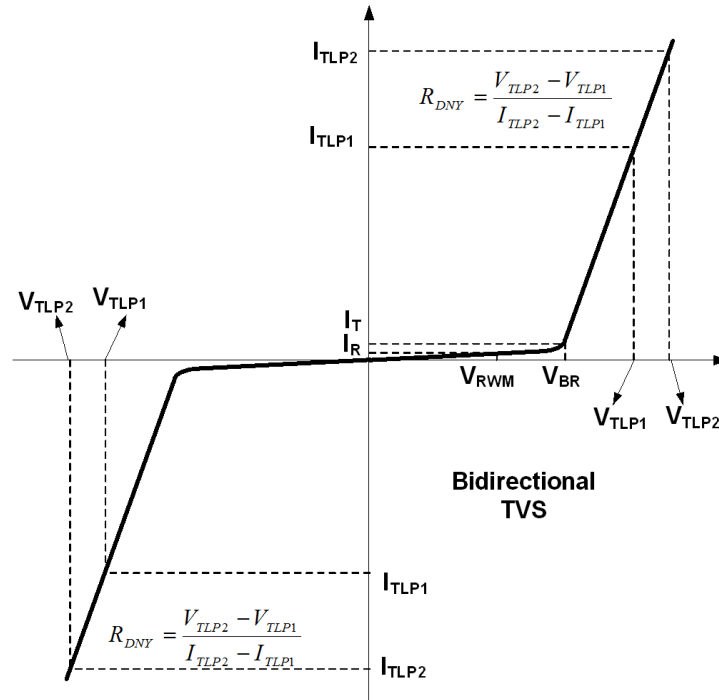

## Electrical Characteristics

| Symbol           | Parameter  | Condition                                       | Min. | Typ. | Max. | Units |
|------------------|--|---|------|------|------|-------|
| V <sub>RWM</sub> | Reverse Working Voltage  | I/O Pin-to-Ground                               |      |      | 3.3  | V     |
| V <sub>BR</sub>  | Reverse Breakdown Voltage  | I <sub>T</sub> =1mA, I/O Pin-to-Ground          | 5.5  |      |      | V     |
| I <sub>R</sub>   | Reverse Leakage Current  | V <sub>RWM</sub> =3.3V, I/O Pin-to-Ground       |      | 1    | 100  | nA    |
| V <sub>CL</sub>  | Clamping Voltage <sup>(3)</sup><br>(100ns Transmission Line Pulse,<br>I/O Pin-to-Ground) | I <sub>TLP</sub> =1A                            |      | 8    | 11   | V     |
|                  |  | I <sub>TLP</sub> =16A                           |      | 17   | 22   | V     |
|                  | Clamping Voltage <sup>(3)</sup><br>(IEC61000-4-5, 8/20μs,<br>I/O Pin-to-Ground)          | I <sub>PP</sub> =4A                             |      | 15   | 18   | V     |
| R <sub>DNY</sub> | Dynamic Resistance <sup>(3)</sup>  | I <sub>TLP</sub> =1A to 16A                     |      | 0.3  |      | Ω     |
| C <sub>J</sub>   | Junction Capacitance   | V <sub>I/O</sub> =0V, f=1MHz, I/O Pin-to-Ground |      | 6    | 7.5  | pF    |

**Note:**

3. These specifications are guaranteed by design and characterization.

## Typical Performance Characteristics

$T_A = 25^\circ\text{C}$ , unless otherwise specified.

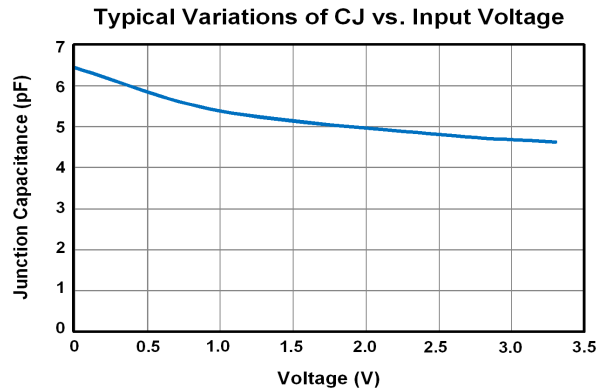
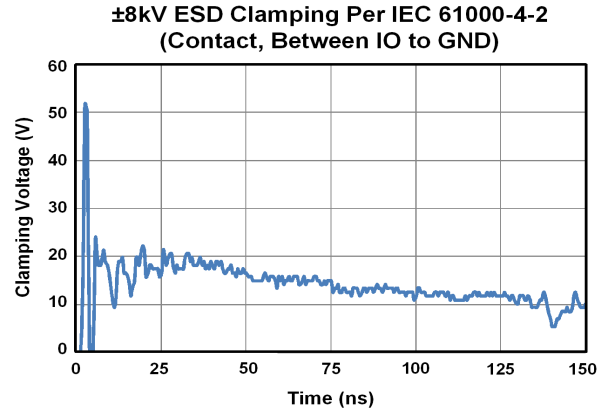
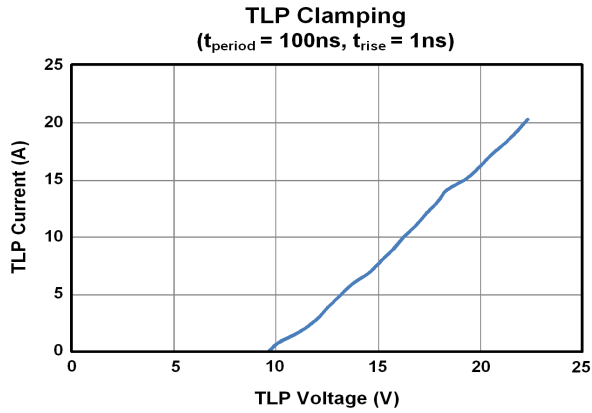

Package Dimension, DFN 0.62 x 0.32

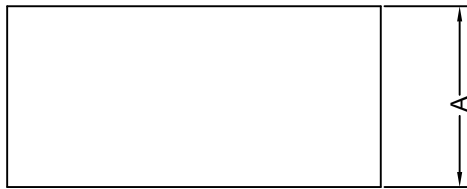
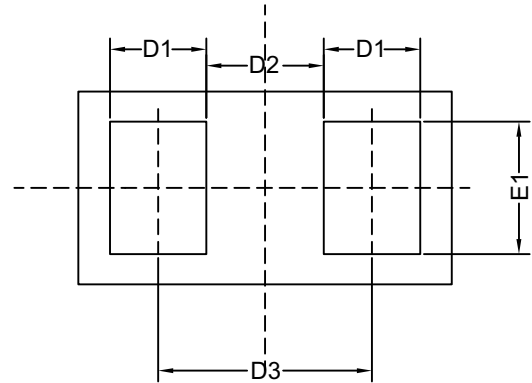
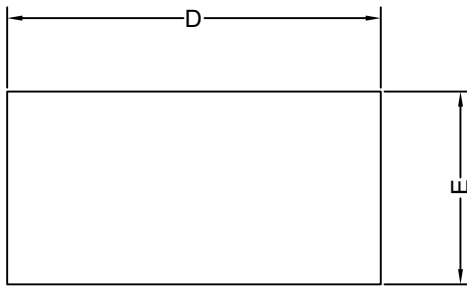

RECOMMEND LAND PATTERN

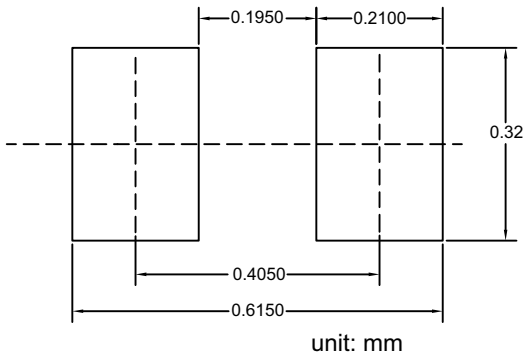

| SYMBOLS | DIMENSIONS IN MILLIMETERS |       |       | DIMENSIONS IN INCHES |        |        |
|---------|---------------------------|-------|-------|----------------------|--------|--------|
|         | MIN                       | NOM   | MAX   | MIN                  | NOM    | MAX    |
| A       | 0.27                      | 0.30  | 0.33  | 0.0106               | 0.0118 | 0.0130 |
| D       | 0.57                      | 0.62  | 0.67  | 0.0224               | 0.0244 | 0.0264 |
| D1      | 0.11                      | 0.16  | 0.21  | 0.0043               | 0.0063 | 0.0083 |
| D2      | 0.145                     | 0.195 | 0.245 | 0.0057               | 0.0077 | 0.0097 |
| D3      | 0.305                     | 0.355 | 0.405 | 0.0120               | 0.0140 | 0.0160 |
| E       | 0.27                      | 0.32  | 0.37  | 0.0106               | 0.0126 | 0.0146 |
| E1      | 0.17                      | 0.22  | 0.27  | 0.0067               | 0.0087 | 0.0107 |

NOTE

1. ALL DIMENSIONS ARE IN MILLIMETERS.
2. DIMENSIONS ARE INCLUSIVE OF PLATING.
3. PACKAGE BODY SIZES EXCLUDE MOLD FLASH AND GATE BURRS.  
MOLD FLASH AT THE NON-LEAD SIDES SHOULD BE LESS THAN 6MIL EACH.
4. CONTROLLING DIMENSIONS IN MILLIMETER.  
CONVERTED INCH DIMENSIONS ARE NOT NECESSARILY EXACT.
5. PADDLE EXPOSED ON BOTTOM.

**Tape and Reel Dimensions, DFN 0.62 x 0.32**

**Carrier Tape**

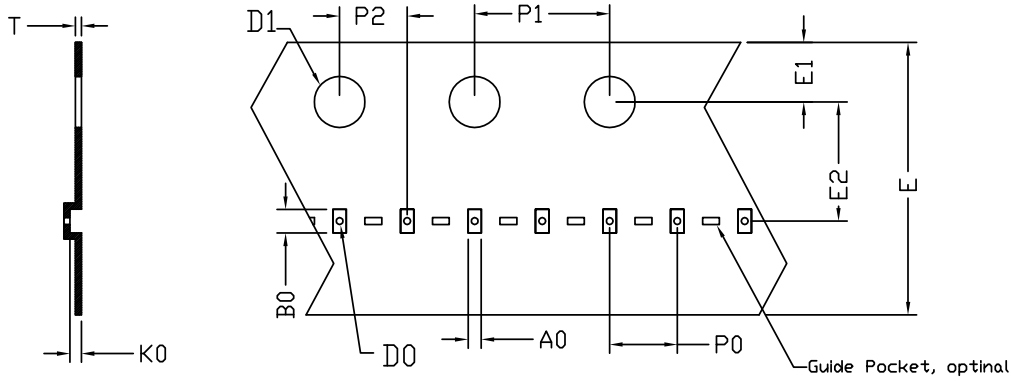

UNIT: MM

| PACKAGE                | A0            | B0            | K0                     | D0            | D1                   | E             | E1            | E2            | P0            | P1            | P2            | T             |
|------------------------|---------------|---------------|------------------------|---------------|----------------------|---------------|---------------|---------------|---------------|---------------|---------------|---------------|
| DFN0.62x0.32<br>(8 mm) | 0.39<br>±0.03 | 0.69<br>±0.03 | 0.34<br>+0.03<br>-0.01 | 0.20<br>±0.05 | 1.50<br>+0.1<br>-0.0 | 8.00<br>±0.10 | 1.75<br>±0.10 | 3.50<br>±0.03 | 2.00<br>±0.05 | 4.00<br>±0.05 | 2.00<br>±0.05 | 0.20<br>±0.05 |

**Reel**

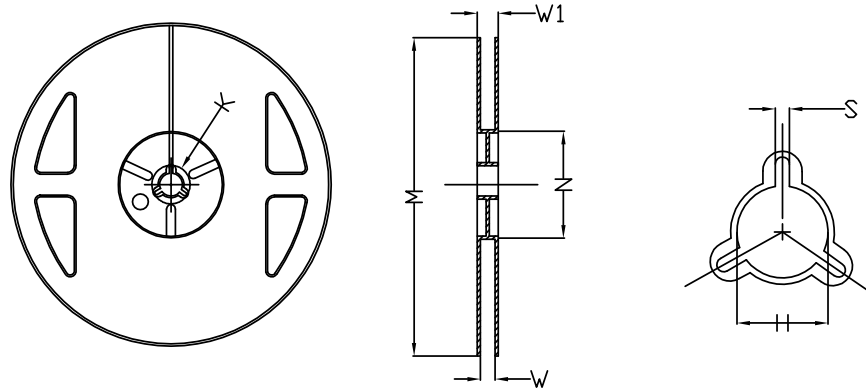

UNIT: MM

| TAPE SIZE | REEL SIZE | M                | N               | W           | W1           | H             | K             | S           |
|-----------|-----------|------------------|-----------------|-------------|--------------|---------------|---------------|-------------|
| 8 mm      | Ø180      | Ø180<br>+0<br>-3 | Ø60<br>+1<br>-0 | 9.0<br>±0.3 | 11.4<br>±1.0 | Ø13.0<br>±0.2 | Ø21.0<br>±0.5 | 2.0<br>±0.5 |

**Leader / Trailer & Orientation**

Unit Per Reel: 10000pcs

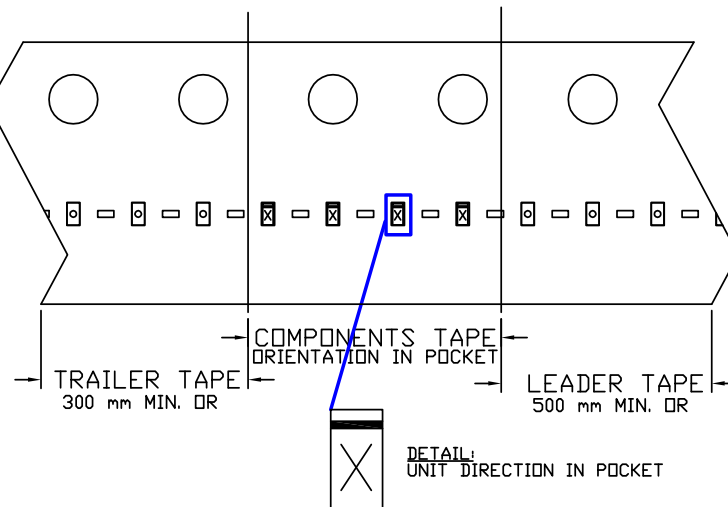

**Part Marking**

**DFN0.62x0.32**

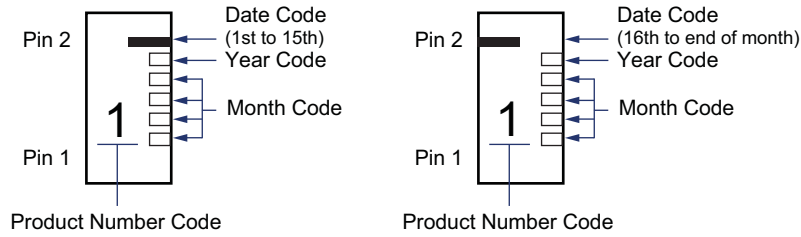

**Alpha & Omega Semiconductor reserves the right to make changes to this data sheet at any time without notice.**

**LIFE SUPPORT POLICY**

**ALPHA & OMEGA SEMICONDUCTOR PRODUCTS ARE NOT AUTHORIZED FOR USE AS CRITICAL COMPONENTS IN LIFE SUPPORT DEVICES OR SYSTEMS.**

As used herein:

1. Life support devices or systems are devices or systems which, (a) are intended for surgical implant into the body or (b) support or sustain life, and (c) whose failure to perform when properly used in accordance with instructions for use provided in the labeling, can be reasonably expected to result in a significant injury of the user.
2. A critical component in any component of a life support, device, or system whose failure to perform can be reasonably expected to cause the failure of the life support device or system, or to affect its safety or effectiveness.