

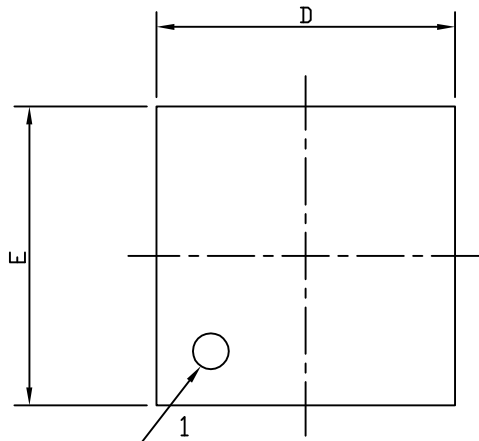

DFN1.6x1.6A_6L_EP1_S PACKAGE OUTLINE



PIN 1 DOT
BY MARKING

TOP VIEW

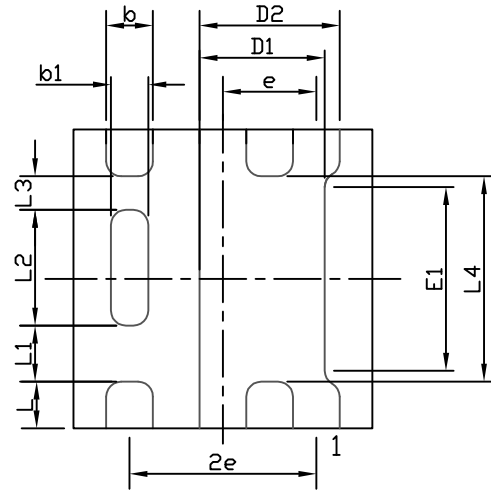

BOTTOM VIEW

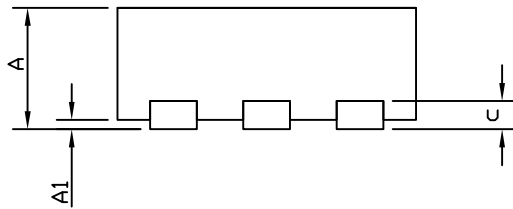

SIDE VIEW

RECOMMENDED LAND PATTERN

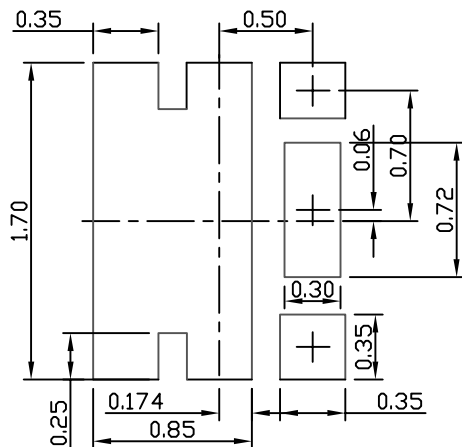

UNIT: mm

SYMBOLS	DIMENSIONS IN MILLIMETERS			DIMENSIONS IN INCHES		
	MIN	NOM	MAX	MIN	NOM	MAX
A	0.50	0.55	0.60	0.020	0.022	0.024
A1	0.00	---	0.05	0.000	---	0.002
b	0.22	0.25	0.28	0.009	0.010	0.011
b1	0.17	0.20	0.23	0.007	0.008	0.009
c	0.152 Ref.			0.006 Ref.		
D	1.55	1.60	1.65	0.061	0.063	0.065
D1	0.67 TYP			0.026 TYP		
D2	0.75 TYP			0.030 TYP		
E	1.55	1.60	1.65	0.061	0.063	0.065
E1	0.98 TYP			0.039 TYP		
e	0.50 BSC			0.020 BSC		
L	0.20	0.25	0.30	0.008	0.010	0.012
L1	0.25	0.30	0.35	0.010	0.012	0.014
L2	0.57	0.62	0.67	0.022	0.024	0.026
L3	0.13	0.18	0.23	0.005	0.007	0.009
L4	1.05	1.10	1.15	0.041	0.043	0.045

NOTE

1. CONTROLLING DIMENSION IS MILLIMETER.
CONVERTED INCH DIMENSIONS ARE NOT NECESSARILY EXACT.