

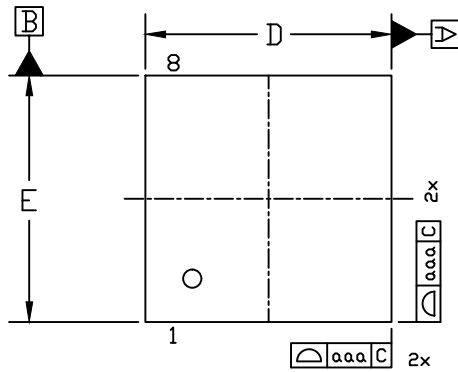

DFN3.3x3.3A\_8L\_EP2\_S PACKAGE OUTLINE

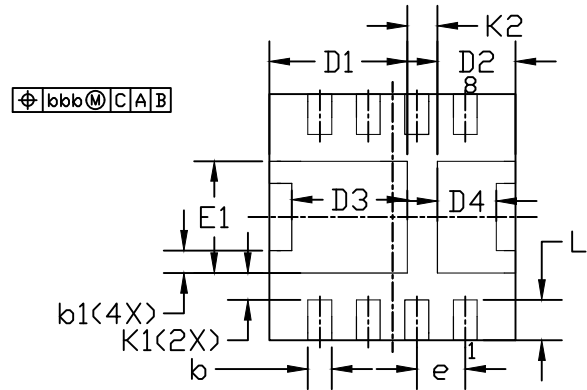

TOP VIEW



BOTTOM VIEW

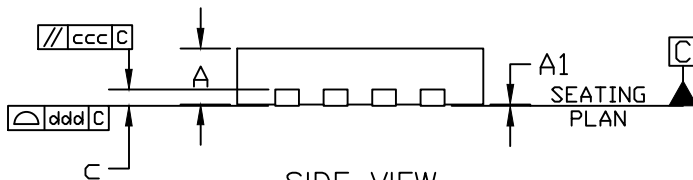

SIDE VIEW

RECOMMENDED LAND PATTERN

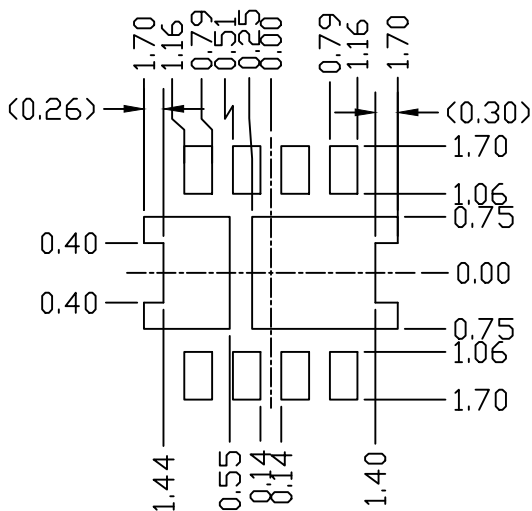

UNIT: mm

SYMBOLS	DIMENSIONS IN MILLIMETERS			DIMENSIONS IN INCHES		
	MIN	NOM	MAX	MIN	NOM	MAX
A	0.65	0.75	0.85	0.026	0.030	0.033
A1	0.00	0.02	0.05	0.000	0.001	0.002
b	0.27	0.32	0.37	0.011	0.013	0.015
b1	0.25	0.30	0.35	0.010	0.012	0.014
c	0.203BSC			0.008BSC		
D	3.20	3.30	3.40	0.126	0.130	0.134
D1	1.75	1.85	1.95	0.069	0.073	0.077
D2	0.95	1.05	1.15	0.037	0.041	0.045
D3	1.45	1.55	1.65	0.057	0.061	0.065
D4	0.69	0.79	0.89	0.027	0.031	0.035
E	3.20	3.30	3.40	0.126	0.130	0.134
E1	1.40	1.50	1.60	0.055	0.059	0.063
e	0.65BSC			0.026BSC		
L	0.44	0.54	0.64	0.017	0.021	0.025
K1	0.26	0.36	0.46	0.010	0.014	0.018
K2	0.30	0.40	0.50	0.012	0.016	0.020
aaa	0.15			0.006		
bbb	0.10			0.004		
ccc	0.10			0.004		
ddd	0.08			0.003		

NOTE

1. CONTROLLING DIMENSION IS MILLIMETER.  
CONVERTED INCH DIMENSIONS ARE NOT NECESSARILY EXACT.