

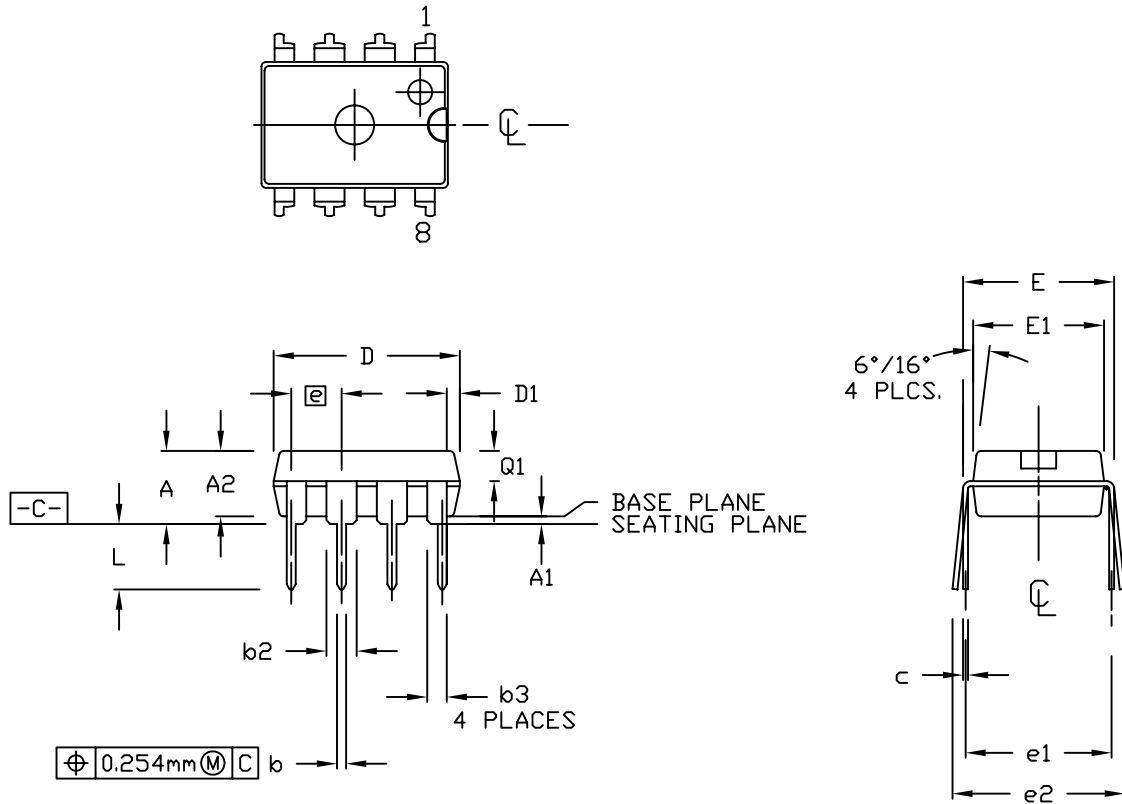

PDIP8 PACKAGE OUTLINE

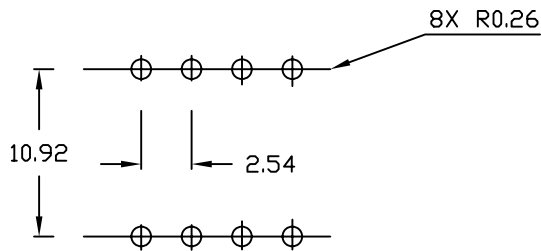

RECOMMENDED LAND PATTERN



UNIT: mm

NOTE

1. PACKAGE BODY SIZES EXCLUDE MOLD FLASH AND GATE BURRS. MOLD FLASH AT THE NON-LEAD SIDES SHOULD BE LESS THAN 10 MILS EACH
2. DIMENSION L IS MEASURED IN SEATING PLANE GAUGE
3. TOLERANCE 0.10 mm UNLESS OTHERWISE SPECIFIED
4. CONTROLLING DIMENSION IS MILLIMETER. CONVERTED INCH DIMENSIONS ARE NOT NECESSARILY EXACT
5. REFER TO JEDEC MS-001

SYMBOL	DIMENSION IN MILLIMETERS			DIMENSIONS IN INCHES		
	MIN.	NOM.	MAX.	MIN.	NOM.	MAX.
A			4.32			.170
A 1	0.38			.015		
A 2	2.92	3.30	4.95	.115	.130	.195
b	0.41	0.46	0.51	.016	.018	.020
b 2	1.40	1.52	1.65	.055	.060	.065
b 3	0.76	0.99	1.14	.030	.039	.045
c	0.20	0.25	0.30	.008	.010	.012
D	9.14	9.27	9.65	.360	.365	.380
D 1	0.46	0.58	0.71	.018	.023	.028
E	7.62		8.26	.300		.325
E 1	6.10	6.40	6.60	.240	.252	.260
e	2.54 BSC			.100 BSC		
e 1	7.62 BSC			.300 BSC		
e 2			10.92			.430
L	3.18		3.43	.125		.135
Q 1	1.40	1.52	1.65	.055	.060	.065