

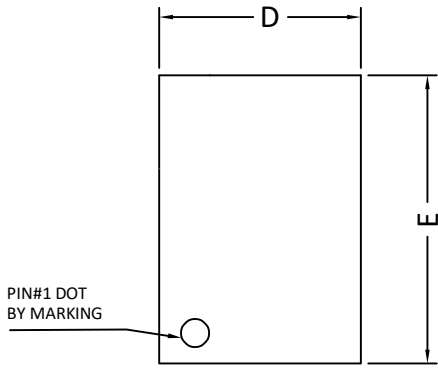

QFN3.5x5_23L_EP2_S PACKAGE OUTLINE

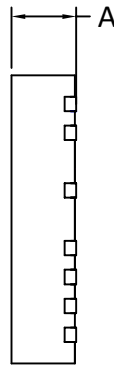

TOP VIEW



SIDE VIEW

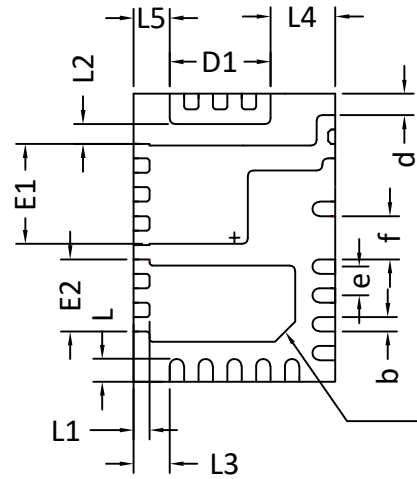

C.0.25

BOTTOM VIEW

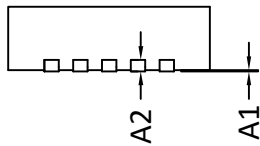

SIDE VIEW

RECOMMENDED LAND PATTERN

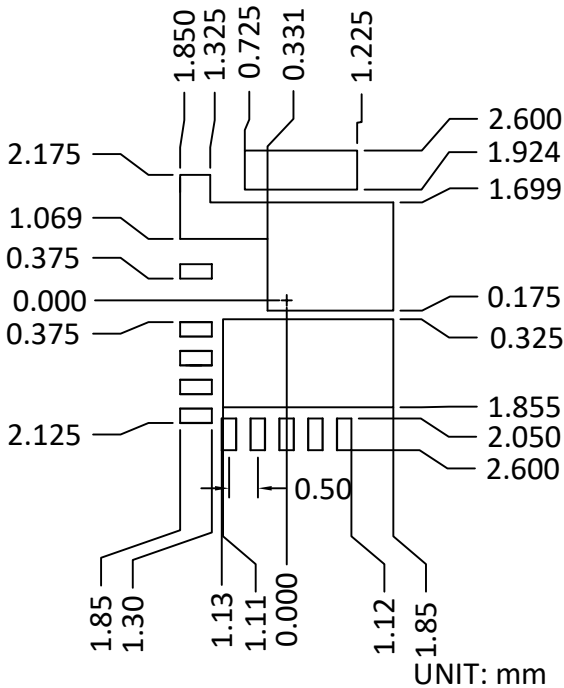

SYMBOLS	DIMENSION IN MM			DIMENSION IN INCHES		
	MIN	NOM	MAX	MIN	NOM	MAX
A	1.00	1.10	1.20	0.039	0.043	0.047
A1	0.00	-	0.05	0.000	-	0.002
A2	0.2REF			0.008REF		
E	4.90	5.00	5.10	0.193	0.197	0.201
E1	1.63	1.73	1.83	0.064	0.068	0.072
E2	1.15	1.25	1.35	0.045	0.049	0.053
D1	1.65	1.75	1.85	0.065	0.069	0.073
D	3.40	3.50	3.60	0.134	0.138	0.142
L	0.35	0.40	0.45	0.014	0.016	0.018
L1	0.22	0.27	0.32	0.009	0.011	0.013
L2	0.30	0.35	0.40	0.012	0.014	0.016
L3	0.58	0.63	0.68	0.023	0.025	0.027
L4	1.02	1.12	1.22	0.040	0.044	0.048
L5	0.58	0.63	0.68	0.023	0.025	0.027
b	0.20	0.25	0.30	0.008	0.010	0.012
d	0.33	0.38	0.43	0.013	0.015	0.017
f	0.70	0.75	0.80	0.028	0.030	0.031
e	0.50BSC			0.02BSC		

NOTE
CONTROLLING DIMENSION IS MILLIMETER.
CONVERTED INCH DIMENSIONS ARE NOT NECESSARILY EXACT.