

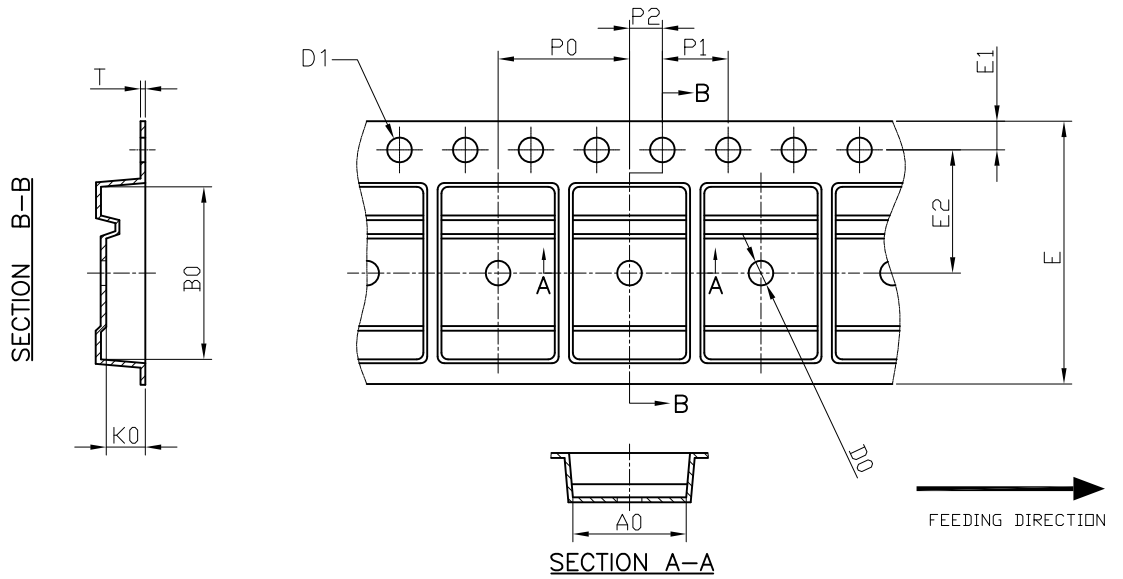

DPAK Carrier Tape



UNIT: MM

PACKAGE	A0	B0	K0	D0	D1	E	E1	E2	P0	P1	P2	T
DPAK (16 mm)	6.90 ±0.10	10.50 ±0.10	2.50 ±0.10	1.50 +0.1 -0	1.50 +0.1 -0	16.00 ±0.30	1.75 ±0.10	7.50 ±0.10	8.00 ±0.10	4.00 ±0.10	2.00 ±0.10	0.30 ±0.05

DPAK Reel

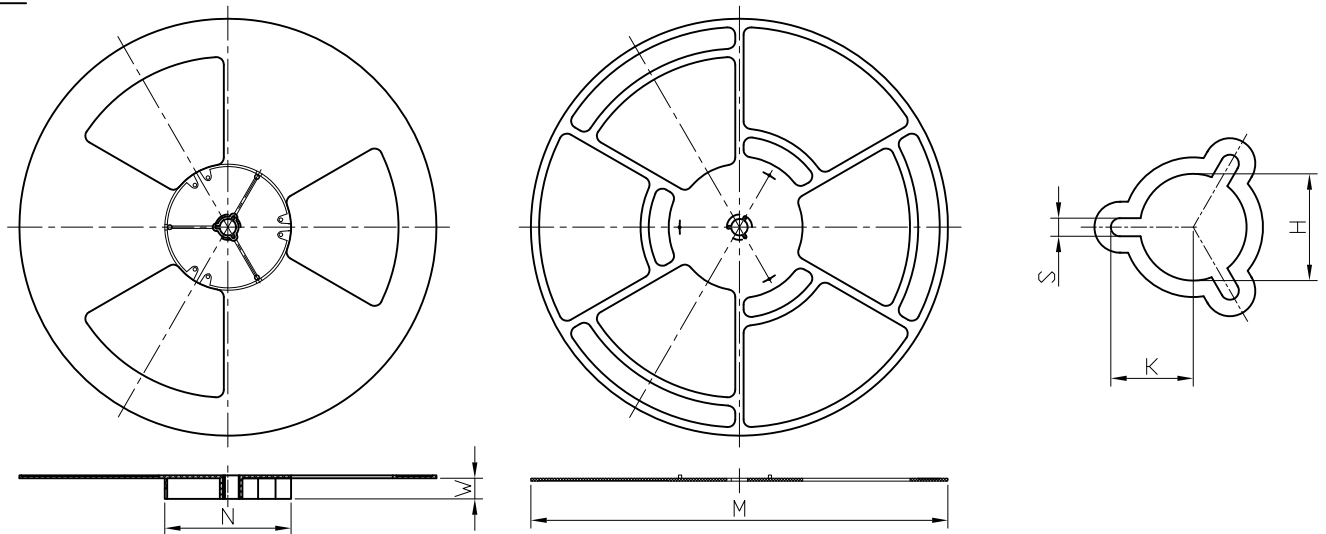

UNIT: MM

TAPE SIZE	REEL SIZE	M	N	W	H	K	S
16 mm	ø330	ø330.00 +0.25 -4.00	ø100.00 ±0.2	16.4 +2.0 -0.0	ø13.00 +0.50 -0.20	10.5 ±0.25	2.2 ±0.25

DPAK Tape

Leader / Trailer
& Orientation

Unit Per Reel:
2500pcs

