

Features

- Proprietary α SiC MOSFET technology
- Low loss, with low $R_{DS, ON}$
- Fast switching with low R_G and low capacitance
- Flexible gate voltage range ($V_{GS} = 15$ to $18V$)
- Low reverse recovery diode (Q_{rr})
- AEC-Q101 Automotive Qualified

Product Summary

$V_{DS} @ T_{J, max}$	1200V
I_{DM}	330A
$R_{DS(ON), TYP}$	20m Ω
Q_{rr}	152nC
$E_{OSS} @ 800V$	59 μ J
100% UIS Tested	

Applications

- xEV Charger
- Electric Vehicle Supply Equipment (EVSE)
- Motor Drives
- Automotive Inverters



Pin Configuration

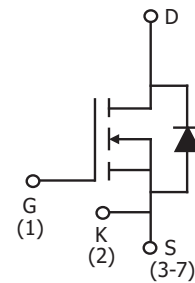
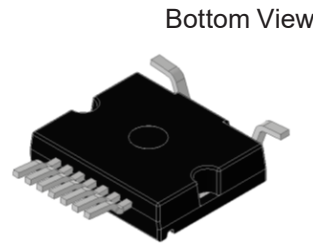
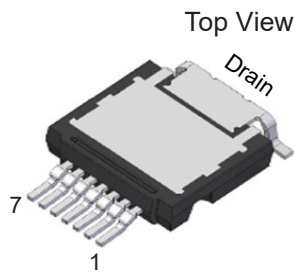

Ordering Part Number	Package Type	Form	Shipping Quantity
AOBT020V120X3Q	T2PAK	Tape and Reel	600/Reel

Absolute Maximum Ratings

($T_A = 25^\circ C$, unless otherwise noted)

Symbol	Parameter	AOBT020V120X3Q	Units
V_{DS}	Drain-Source Voltage	1200	V
$V_{GS, MAX}$	Gate Source Voltage	Maximum	-8/+23
$V_{GS, OP, TRANS}$		Max Transient ^(A)	-10/+25
$V_{GS, OP, ON}$		Recommended Operating Range ^(B)	15...18
$V_{GS, OP, OFF}$			-5...-3
I_D	Continuous Drain Current ^(C)	$T_C = 25^\circ C, V_{GS} = 18V$	114
		$T_C = 100^\circ C, V_{GS} = 18V$	81
I_{DM}	Pulsed Drain Current ^(D)	330	A
I_{SD}	Continuous Body Diode Forward Current $V_{GS} = -3V, T_C = 25^\circ C$	96	A
E_{AS}	Single Pulsed Avalanche Energy ^(F)	1.1	J
P_D	Power Dissipation ^(E)	500	W
T_J, T_{STG}	Junction and Storage Temperature Range	-55 to 175	$^\circ C$
T_L	Maximum lead temperature for soldering purpose, 1/8" from case for 5 seconds	245	$^\circ C$

Thermal Characteristics

Symbol	Parameter	Typ	Max	Units
$R_{\theta JA}$	Maximum Junction-to-Ambient ^(F,G)		40	°C/W
$R_{\theta JC}$	Maximum Junction-to-Case ^(H)	0.25	0.30	°C/W

Electrical Characteristics

($T_A = 25^\circ\text{C}$, unless otherwise noted)

Symbol	Parameter	Conditions	Min	Typ	Max	Units
STATIC PARAMETERS						
BV_{DSS}	Drain-Source Breakdown Voltage	$I_D = 250\mu\text{A}$, $V_{GS} = 0\text{V}$, $T_J = 25^\circ\text{C}$	1200			V
		$I_D = 250\mu\text{A}$, $V_{GS} = 0\text{V}$, $T_J = 175^\circ\text{C}$	1200			
I_{DSS}	Zero Gate Voltage Drain Current	$V_{DS} = 1200\text{V}$, $V_{GS} = 0\text{V}$			100	μA
I_{GSS}	Gate-Body Leakage Current	$V_{DS} = 0\text{V}$, $V_{GS} = +18/-3\text{V}$			± 200	nA
$V_{GS(th)}$	Gate Threshold Voltage	$V_{DS} = V_{GS}$, $I_D = 27\text{mA}$	2.2	3	4.3	V
$R_{DS(ON)}$	Static Drain-Source On-Resistance	$V_{GS} = 15\text{V}$, $I_D = 27\text{A}$	$T_J = 25^\circ\text{C}$	23.5	35	m Ω
			$T_J = 175^\circ\text{C}$	40		
		$V_{GS} = 18\text{V}$, $I_D = 27\text{A}$	$T_J = 25^\circ\text{C}$	20	29	
			$T_J = 175^\circ\text{C}$	38		
g_{FS}	Forward Transconductance	$V_{DS} = 20\text{V}$, $I_D = 27\text{A}$		20		S
V_{SD}	Diode Forward Voltage	$I_S = 27\text{A}$, $V_{GS} = -3\text{V}$		4	5	V
DYNAMIC						
C_{iss}	Input Capacitance	$V_{GS} = 0\text{V}$, $V_{DS} = 800\text{V}$, $f = 100\text{kHz}$		3744		pF
C_{oss}	Output Capacitance			141		pF
C_{rss}	Reverse Transfer Capacitance			15		pF
E_{oss}	C_{oss} Stored Energy			59		μJ
$C_{o(er)}$	Effective output capacitance, energy related ^(L)	$V_{GS} = 0\text{V}$, $V_{DS} = 0$ to 800V , $f = 100\text{kHz}$		181		pF
$C_{o(tr)}$	Effective output capacitance, time related ^(M)			243		pF
R_G	Gate Resistance	$f = 1\text{MHz}$		1.5		Ω

Electrical Characteristics (Continued)

 (T_A = 25°C, unless otherwise noted)

Symbol	Parameter	Conditions	Min	Typ	Max	Units
SWITCHING						
Q _g	Total Gate Charge			154		nC
Q _{gs}	Gate Source Charge	V _{GS} = -3/+18V, V _{DS} = 800V, I _D = 27A		35		nC
Q _{gd}	Gate Drain Charge			40		nC
t _{d(on)}	Turn-On Delay Time			15		ns
t _r	Turn-On Rise Time	V _{GS} = -3V/+18V, V _{DS} = 800V, I _D = 30A, R _G = 2Ω		12		ns
t _{D(off)}	Turn-Off Delay Time			25		ns
t _f	Turn-Off Fall Time			9		ns
E _{on}	Turn-On Energy	L _a = 47.5μH		433		μJ
E _{off}	Turn-Off Energy	FWD: AOBT020V120X3Q		40		μJ
E _{tot}	Total Switching Energy			473		μJ
t _{rr}	Body Diode Reverse Recovery Time	I _F = 30A, di/dt = 1500A/μs, V _{GS} = -3V V _{DS} = 800V		19		ns
I _{rm}	Peak Reverse Recovery Current			15		A
Q _{rr}	Body Diode Reverse Recovery Charge			152		nC

Notes:

- A. t_{ON} < 1μs, t < 25hrs over lifetime. t_{ON} is duration of V_{GS} transient and t is total time spent at V_{GS,OP,TRANS} over product lifetime.
- B. Device can be operated at V_{GS} = 0/18V. Actual operating V_{GS} will depend on application specifics such as parasitic inductance and dV/dt but should not exceed maximum ratings.
- C. Continuous drain current is calculated based on maximum R_{θJC} and typical R_{DSON} at 175°C.
- D. I_{DM} obtained using a V_{GS} = 18V, 10ms pulse, and limiting the device to a maximum junction temperature of 175°C.
- E. The power dissipation P_D is based on T_{J(MAX)} = 175°C, using junction-to-case thermal resistance, and is more useful in setting the upper dissipation limit for cases where additional heatsinking is used.
- F. L = 5mH, I_{AS} = 21A, R_G = 25Ω, Starting T_J = 25°C.
- G. The value of R_{θJA} is measured with the device in a still air environment with T_A = 25°C.
- H. The R_{θJA} is the sum of the thermal impedance from junction to case R_{θJC} and case to ambient.
- I. The value of R_{θJC} is measured with the device mounted to a large heat-sink, assuming a maximum junction temperature of T_{J(MAX)} = 175°C.

Typical Electrical and Thermal Characteristics^(J)

$T_A = 25^\circ\text{C}$, unless otherwise specified.

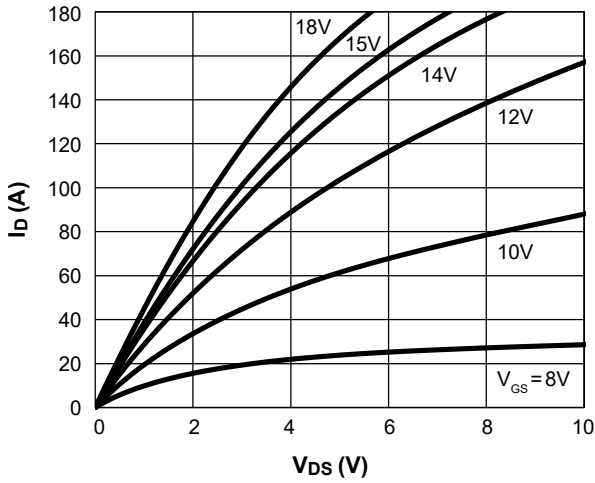

Figure 1. On-Region Characteristics $T_J = 25^\circ\text{C}$

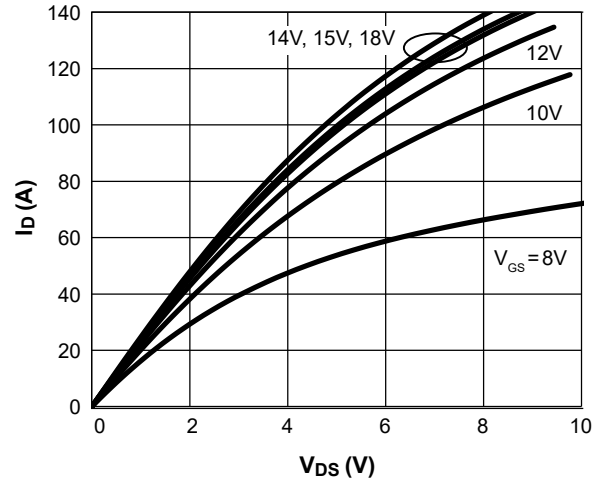

Figure 2. On-Region Characteristics $T_J = 175^\circ\text{C}$

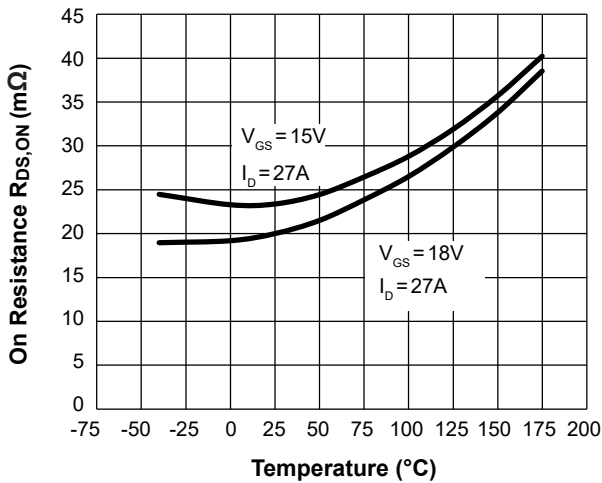

Figure 3. On-Resistance vs. Junction Temperature

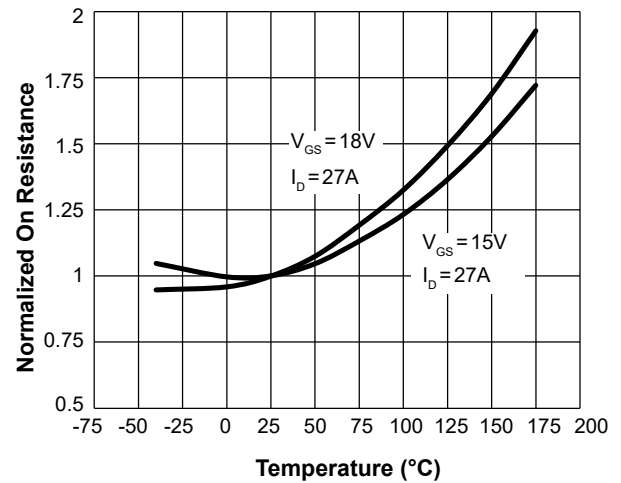

Figure 4. Normalized On-Resistance vs. Junction Temperature

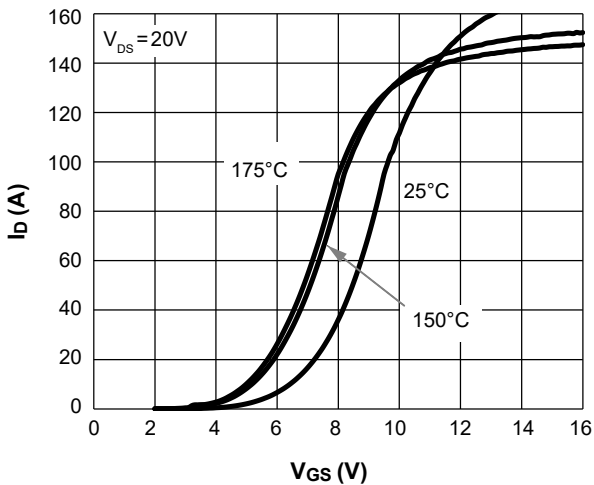

Figure 5. Transfer Characteristics

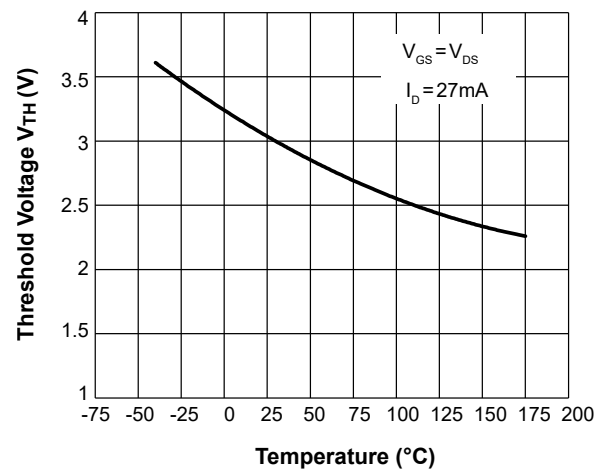

Figure 6. Threshold Voltage vs. Junction Temperature

Typical Electrical and Thermal Characteristics^(J) (Continued)

T_A = 25°C, unless otherwise specified.

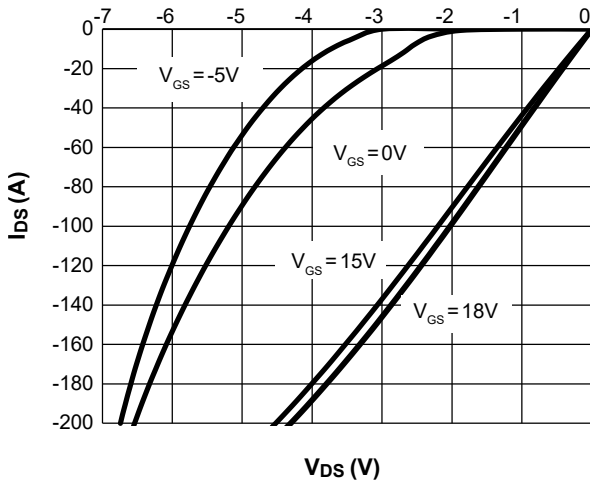

Figure 7. Body-Diode Characteristics at 25°C

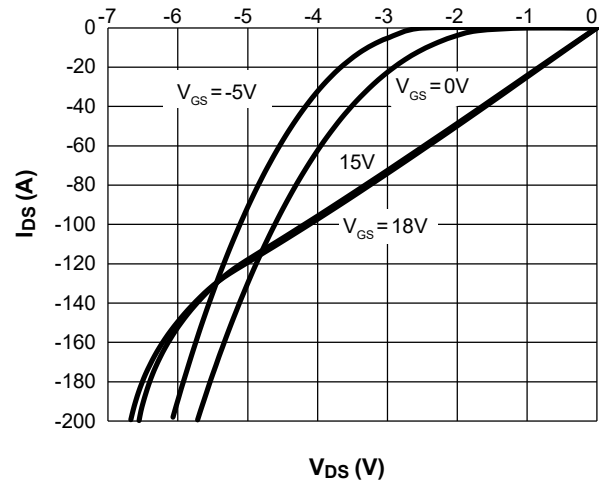

Figure 8. Body-Diode Characteristics at 175°C

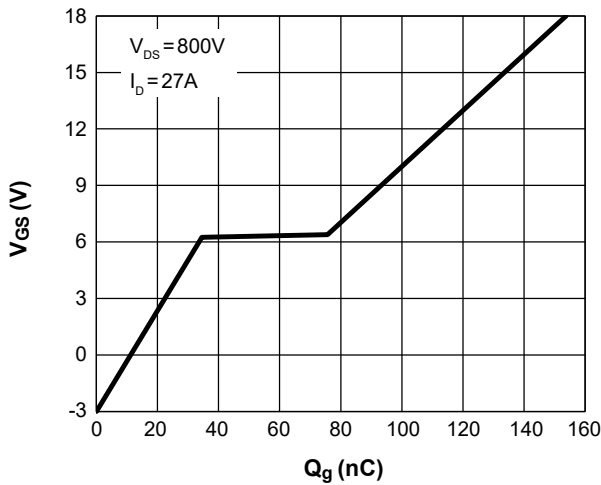

Figure 9. Gate-Charge Characteristics

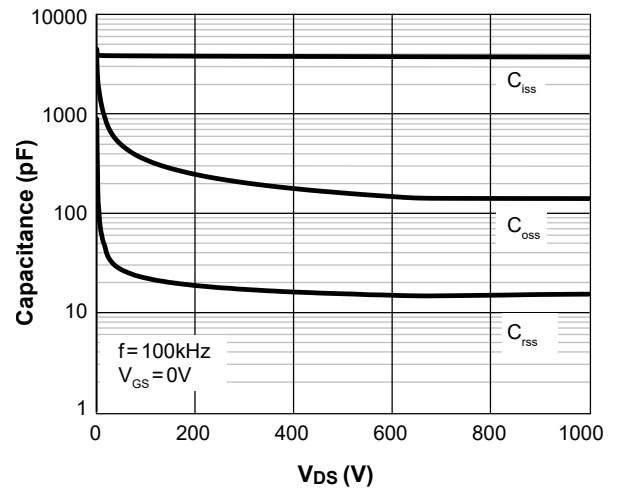

Figure 10. Capacitance Characteristics

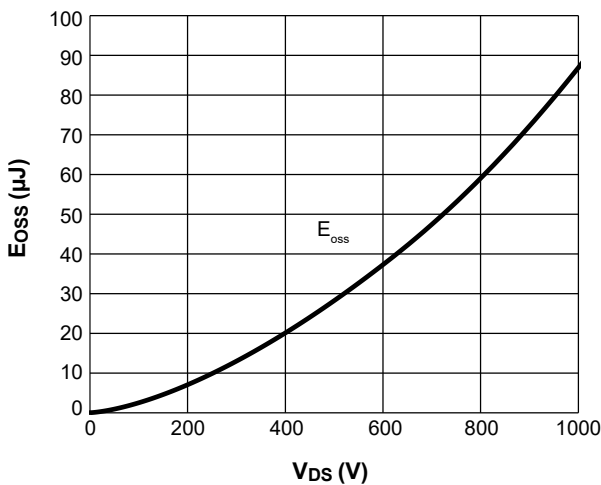

Figure 11. Coss Stored Energy

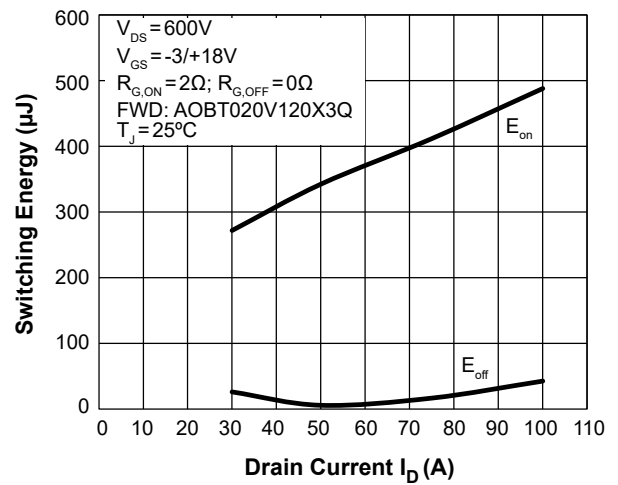

Figure 12. Switching Energy vs. Drain Current

Typical Electrical and Thermal Characteristics (Continued)

T_A = 25°C, unless otherwise specified.

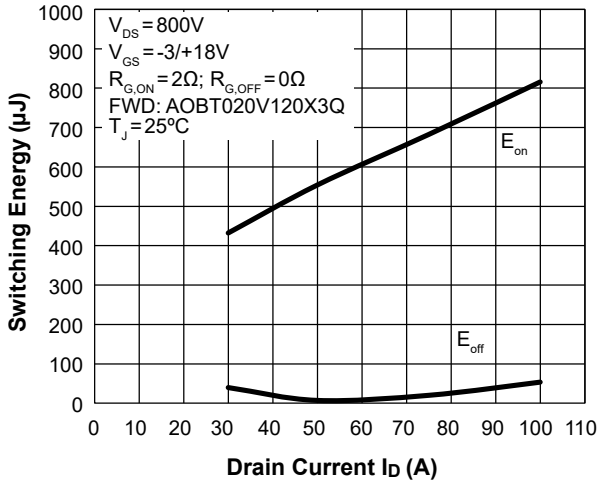

Figure 13. Switching Energy vs. Drain Current

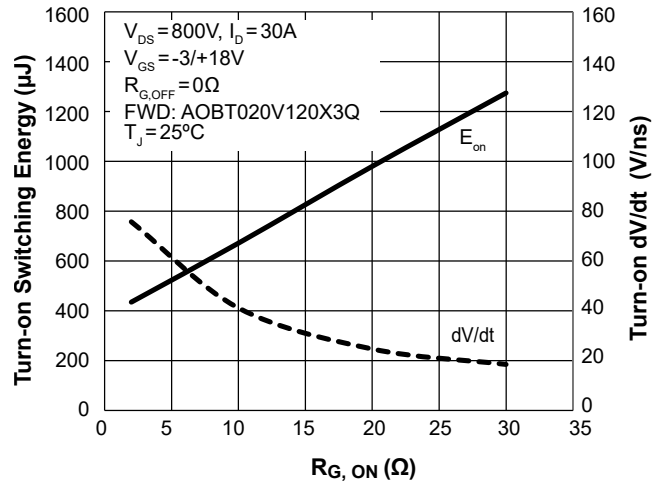

Figure 14. Turn-On Energy and dV/dt vs. External Gate Resistance

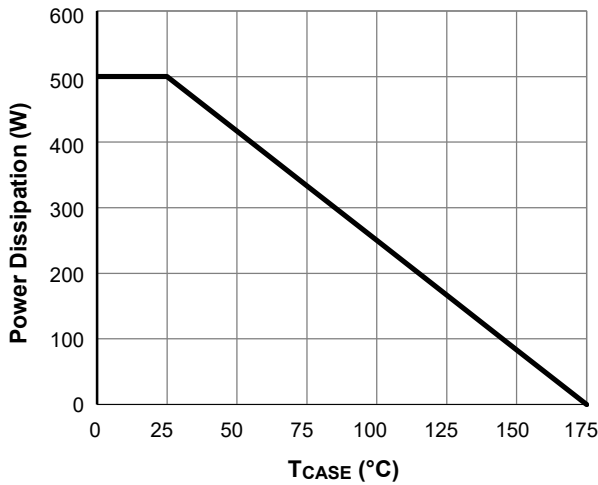

Figure 15. Power De-rating (Note J)

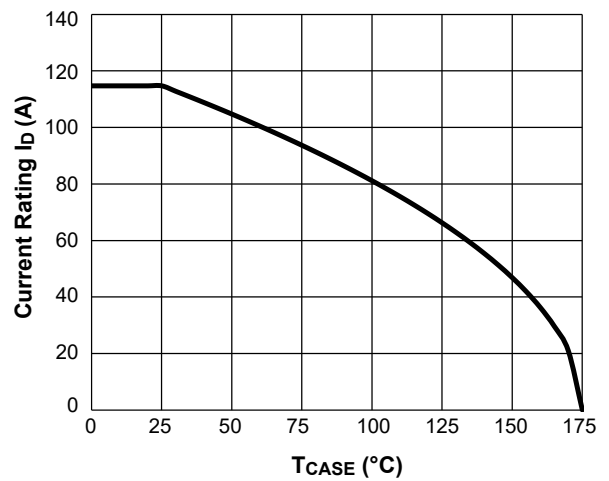

Figure 16. Current De-rating (Note C, K)

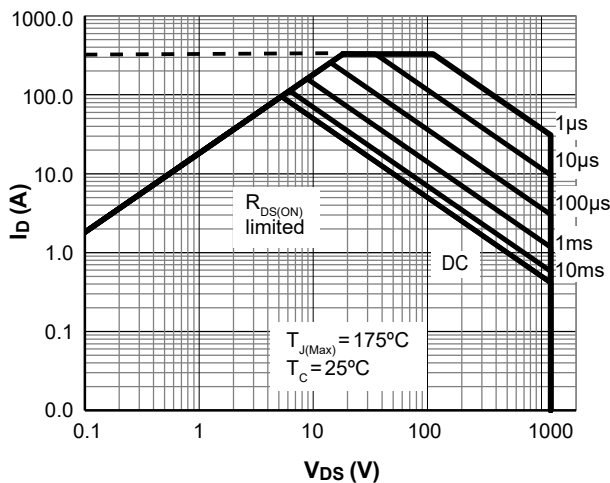

Figure 17. Maximum Forward Biased Safe Operating Area for AOBT020V120X3Q (Note K)

Typical Electrical and Thermal Characteristics (Continued)

T_A = 25°C, unless otherwise specified.

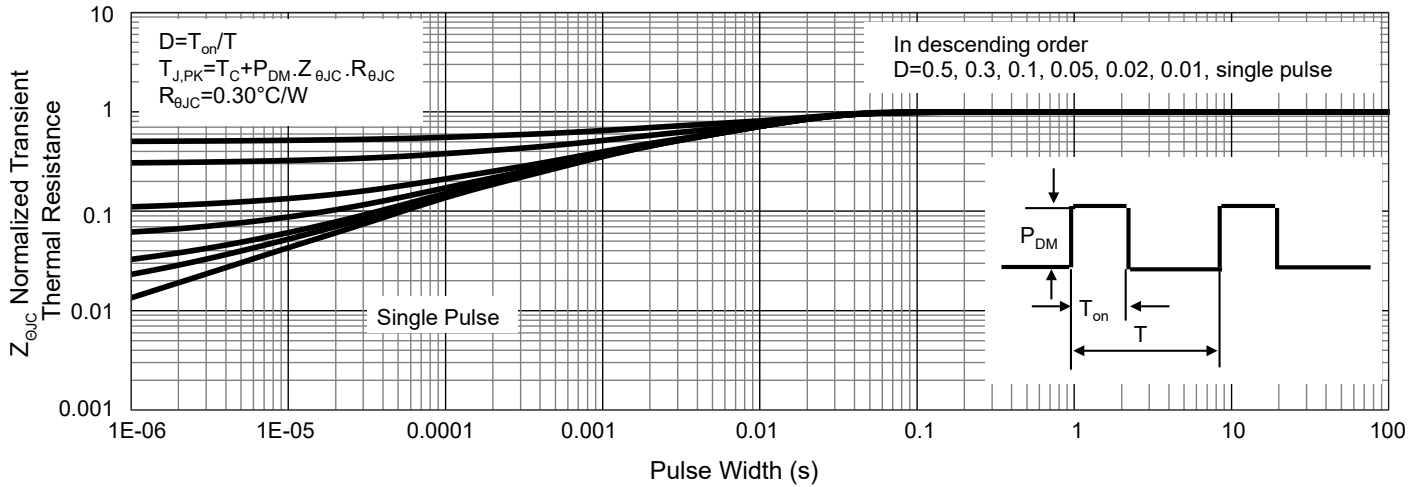

Figure 18. Normalized Maximum Transient Thermal Impedance for AOBT020V120X3Q (Note K)

Notes:

- J. The static characteristics in Figures 1 to 8 are obtained using <300 ms pulses, duty cycle 0.5% max.
- K. These curves are based on R_{θJC} which is measured with the device mounted to a large heatsink, assuming a maximum junction temperature of T_{J(MAX)} = 175°C. The SOA curve provides a single pulse rating.

- L. C_{o(er)} is a fixed capacitance that gives the same stored energy as C_{oss} while V_{DS} is rising from 0 to 80% V_{(BR)DSS}.
- M. C_{o(tr)} is a fixed capacitance that gives the same charging time as C_{oss} while V_{DS} is rising from 0 to 80% V_{(BR)DSS}.

Test Circuits and Waveforms

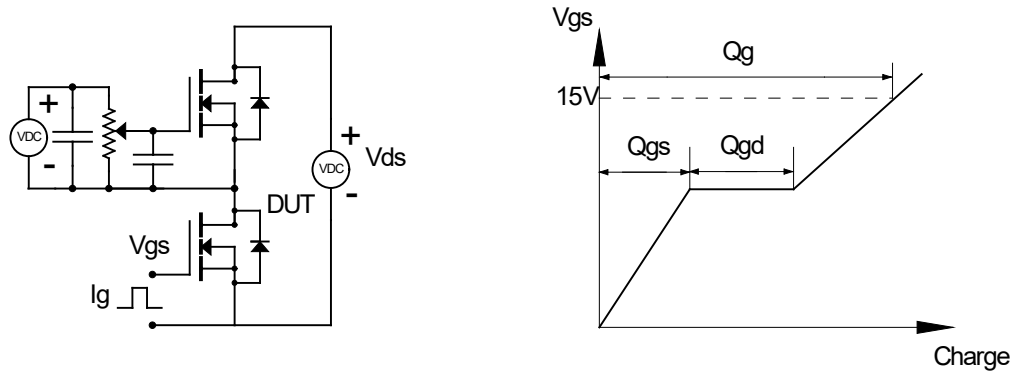

Figure 19. Gate Charge Test Circuits and Waveforms

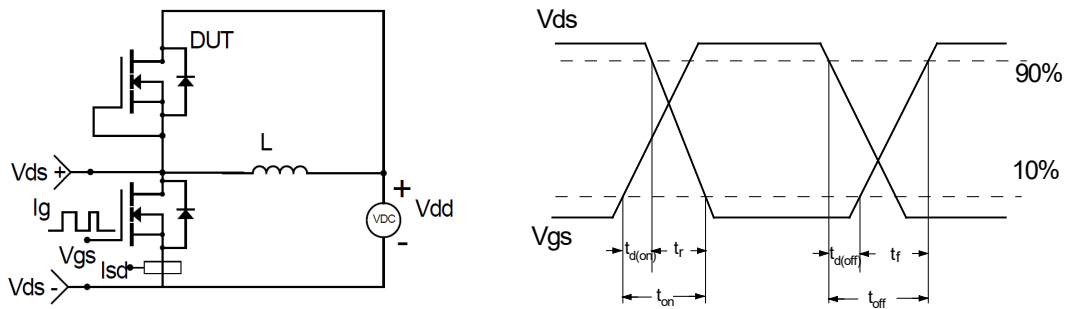

Figure 20. Inductive Switching Test Circuit and Waveforms

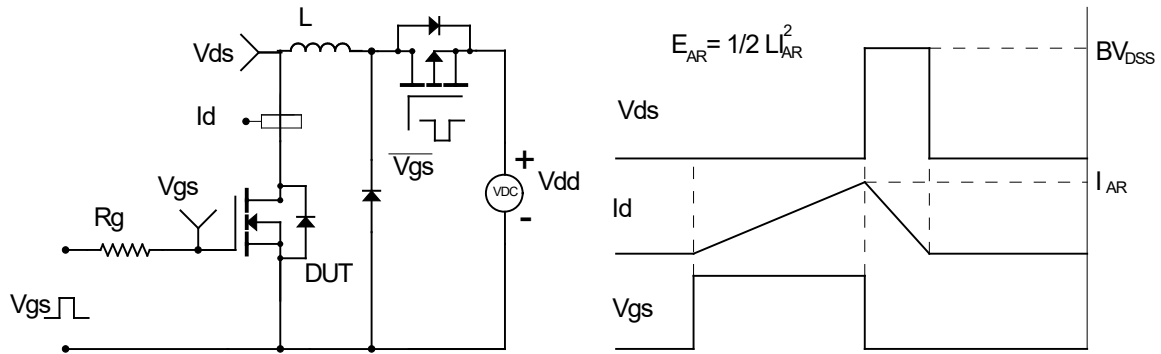

Figure 21. Unclamped Inductive Switching (UIS) Test Circuit and Waveforms

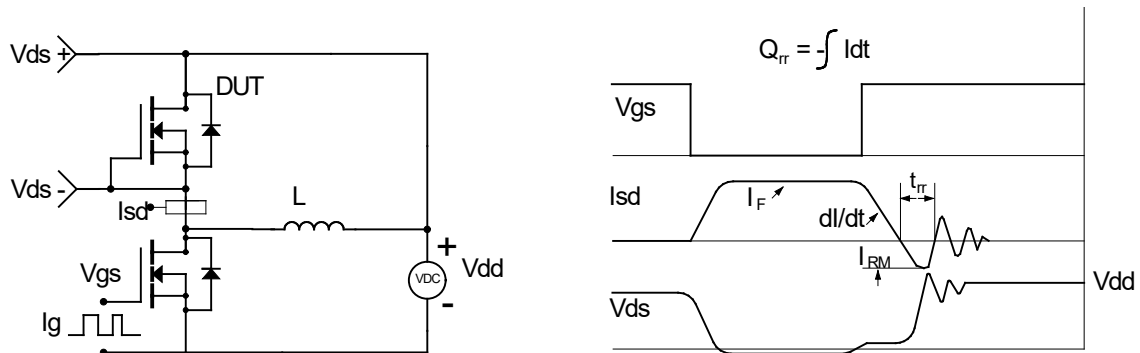
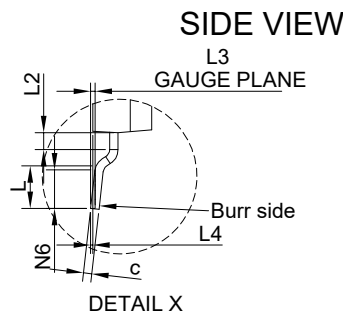
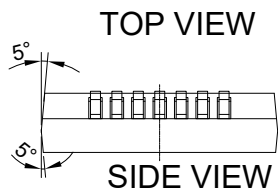
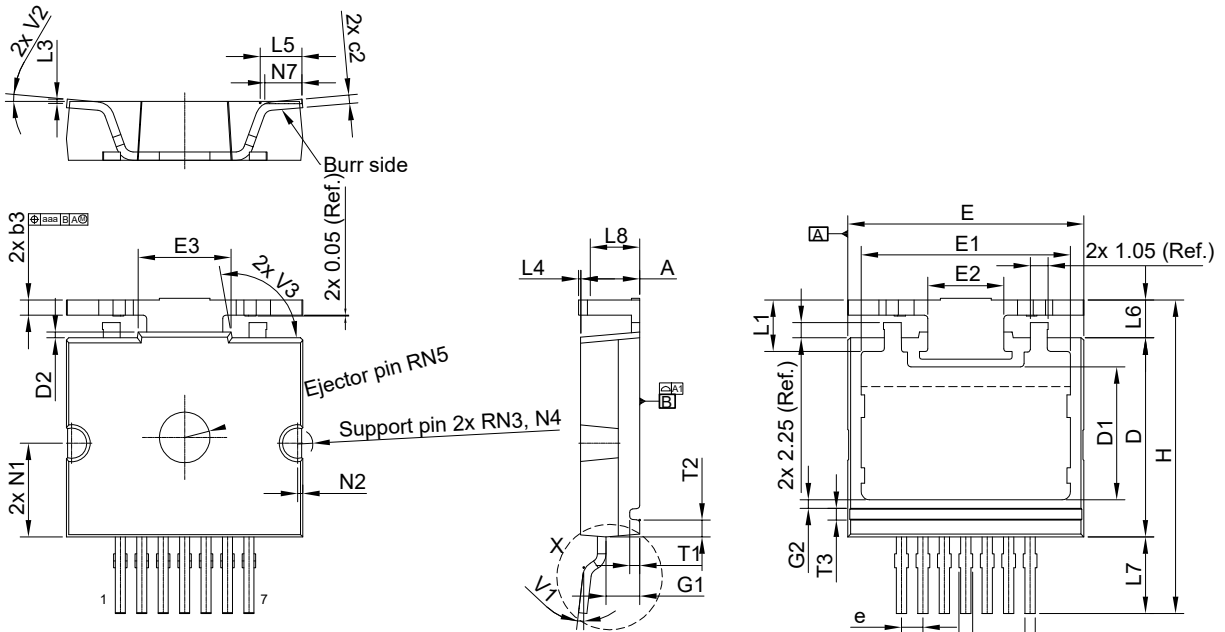
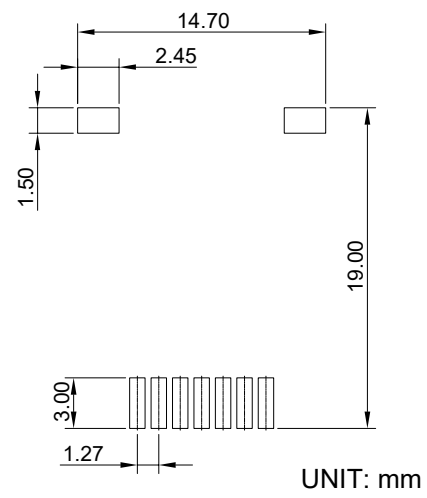

Figure 22. Diode Recovery Test Circuits and Waveforms

Package Dimensions, T2PAK-7L



LAND PATTERN RECOMMENDATIONS



UNIT: mm

SYMBOLS DIMENSION IN MILLIMETERS DIMENSION IN INCHES

SYMBOLS	DIMENSION IN MILLIMETERS			DIMENSION IN INCHES		
	MIN.	NOM.	MAX.	MIN.	NOM.	MAX.
A	3.40	3.50	3.60	0.134	0.138	0.142
A1		0.05			0.002	
b	0.50	0.60	0.70	0.020	0.024	0.028
b2	0.70	0.80	0.90	0.028	0.031	0.035
b3	0.80	0.90	0.98	0.031	0.035	0.039
c	0.40	0.50	0.60	0.016	0.020	0.024
c2	0.40	0.50	0.60	0.016	0.020	0.024
D	11.70	11.80	11.90	0.461	0.465	0.469
D1	7.78	7.88	7.98	0.306	0.310	0.314
D2	0.24	0.34	0.44	0.009	0.013	0.017
E	13.90	14.00	14.10	0.547	0.551	0.555
E1	12.30	12.40	12.50	0.484	0.488	0.492
E2	4.45	4.50	4.55	0.175	0.177	0.179
E3	5.45	5.50	5.55	0.215	0.217	0.219
e		1.27			0.050	
H	18.00	18.58	19.00	0.709	0.731	0.748
L	2.42	2.52	2.62	0.095	0.099	0.103
L1		3.04			0.120	
L2	0.90	1.00	1.10	0.035	0.039	0.043
L3		0.26			0.010	
L4	0.075	0.125	0.175	0.003	0.005	0.007
L5	2.38	2.48	2.58	0.094	0.098	0.102
L6	2.14	2.24	2.34	0.084	0.088	0.092
L7	4.44	4.54	4.64	0.175	0.179	0.183
L8	3.475	3.625	3.775	0.137	0.143	0.149
N1	5.46	5.56	5.66	0.215	0.219	0.223
N2	0.25	0.30	0.35	0.010	0.012	0.014
N3	0.80	0.90	1.00	0.031	0.035	0.039
N4	1.00	1.10	1.20	0.039	0.043	0.047
N5	1.40	1.50	1.60	0.055	0.059	0.063
N6	2.185	2.285	2.385	0.086	0.090	0.094
N7	2.10	2.20	2.30	0.083	0.087	0.091
G1	1.90	2.00	2.10	0.075	0.079	0.083
G2	0.41	0.51	0.61	0.016	0.020	0.024
T1		0.60			0.024	
T2		1.00			0.039	
T3	0.60	0.70	0.80	0.024	0.028	0.031
V1	0°	5°	8°	0°	5°	8°
V2	0°	6°	8°	0°	6°	8°
V3		100°			100°	
aaa		0.10			0.004	

- NOTES:
1. DIMENSION AND TOLERANCE CONFORM TO ASME Y14.5M.
 2. CONTROLLING DIMENSIONS : MILLIMETER. CONVERTED INCH DIMENSION ARE NOT NECESSARILY EXACT.
 3. COPLANARITY APPLIES TO THE EXPOSED PADS AS WELL AS THE TERMINALS.
 4. DIMENSIONS D AND E DO NOT INCLUDE MOLD FLASH, PROTRUSIONS OR GATE BURRS.

Part Marking

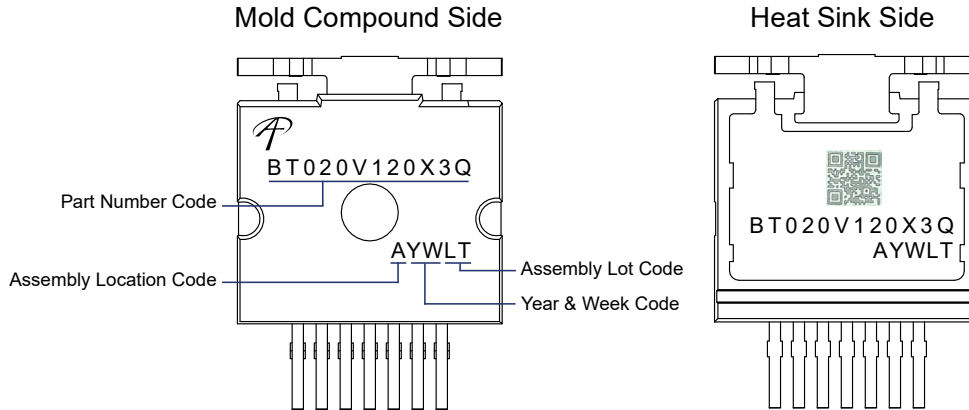

LEGAL DISCLAIMER

Applications or uses as critical components in life support devices or systems are not authorized. Alpha and Omega Semiconductor does not assume any liability arising out of such applications or uses of its products. AOS reserves the right to make changes to product specifications without notice. It is the responsibility of the customer to evaluate suitability of the product for their intended application. Customer shall comply with applicable legal requirements, including all applicable export control rules, regulations and limitations.

AOS' products are provided subject to AOS' terms and conditions of sale which are set forth at:

http://www.aosmd.com/terms_and_conditions_of_sale

LIFE SUPPORT POLICY

ALPHA AND OMEGA SEMICONDUCTOR PRODUCTS ARE NOT AUTHORIZED FOR USE AS CRITICAL COMPONENTS IN LIFE SUPPORT DEVICES OR SYSTEMS.

As used herein:

1. Life support devices or systems are devices or systems which, (a) are intended for surgical implant into the body or (b) support or sustain life, and (c) whose failure to perform when properly used in accordance with instructions for use provided in the labeling, can be reasonably expected to result in a significant injury of the user.
2. A critical component in any component of a life support, device, or system whose failure to perform can be reasonably expected to cause the failure of the life support device or system, or to affect its safety or effectiveness.