

## General Description

The AOZ1037PI-01 is a high efficiency, simple to use, 5A synchronous buck regulator. The AOZ1037PI-01 works from a 4.5V to 18V input voltage range, and provides up to 5A of continuous output current with an output voltage adjustable down to 0.8V.

The AOZ1037PI-01 comes in an exposed pad SO-8 packages and is rated over a -40°C to +85°C ambient temperature range.

## Features

- 4.5 to 18V operating input voltage range
- Synchronous rectification: 55mΩ internal high-side switch and 19mΩ Internal low-side switch
- High efficiency: up to 95%
- Internal soft start
- Active high power good state
- Output voltage adjustable to 0.8V
- 5A continuous output current
- Fixed 500kHz PWM operation
- Cycle-by-cycle current limit
- Pre-bias start-up
- Short-circuit protection
- Thermal shutdown
- Exposed pad SO-8 package

## Applications

- Point of load DC/DC conversion
- LCD TVs
- Set top boxes
- DVD / Blu-ray players/recorders
- Cable modems
- PCIe graphics cards
- Telecom/Networking/Datacom equipment



## Typical Application

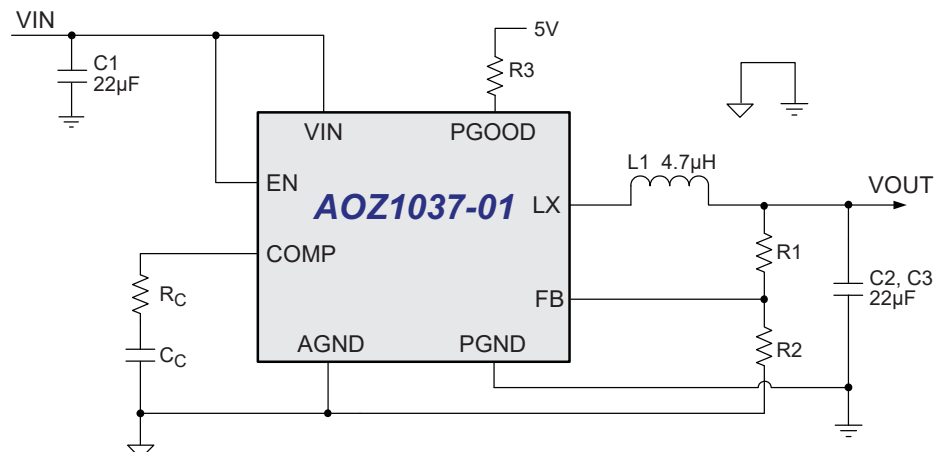

Figure 1. 3.3V/5A Synchronous Buck Regulator

## Ordering Information

Part Number	Ambient Temperature Range	Package	Environmental
AOZ1037PI-01	-40°C to +85°C	EPAD SO-8	Green Product



AOS Green Products use reduced levels of Halogens, and are also RoHS compliant. Please visit <http://www.aosmd.com/media/AOSGreenPolicy.pdf> for additional information.

## Pin Configuration

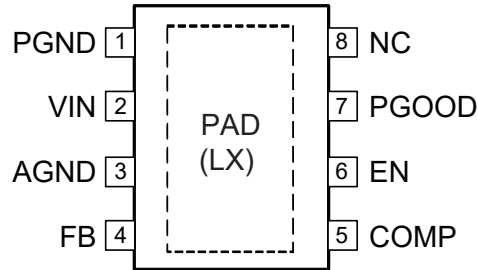

**Exposed Pad SO-8**  
(Top View)

## Pin Description

Pin Number	Pin Name	Pin Function
1	PGND	Power ground. PGND needs to be electrically connected to AGND.
2	V <sub>IN</sub>	Supply voltage input. When V <sub>IN</sub> rises above the UVLO threshold and EN is logic high, the device starts up.
3	AGND	Analog ground. AGND is the reference point for controller section. AGND needs to be electrically connected to PGND.
4	FB	Feedback input. The FB pin is used to set the output voltage via a resistor divider between the output and AGND.
5	COMP	External loop compensation pin. Connect a RC network between COMP and AGND to compensate the control loop.
6	EN	Enable pin. Pull EN to logic high to enable the device. Pull EN to logic low to disable the device. If on/off control is not needed, connect it to V <sub>IN</sub> and do not leave it open.
7	PGOOD	Power Good Output. PGOOD is an open-drain output that indicates the status of output voltage. PGOOD is pulled low when output is below 90% of the normal regulation.
8	NC	No Connect. Pin 8 is not internally connected.
Pad	LX	Switching node. LX is the drain of the internal PFET. LX is used as the thermal pad of the power stage.

## Block Diagram

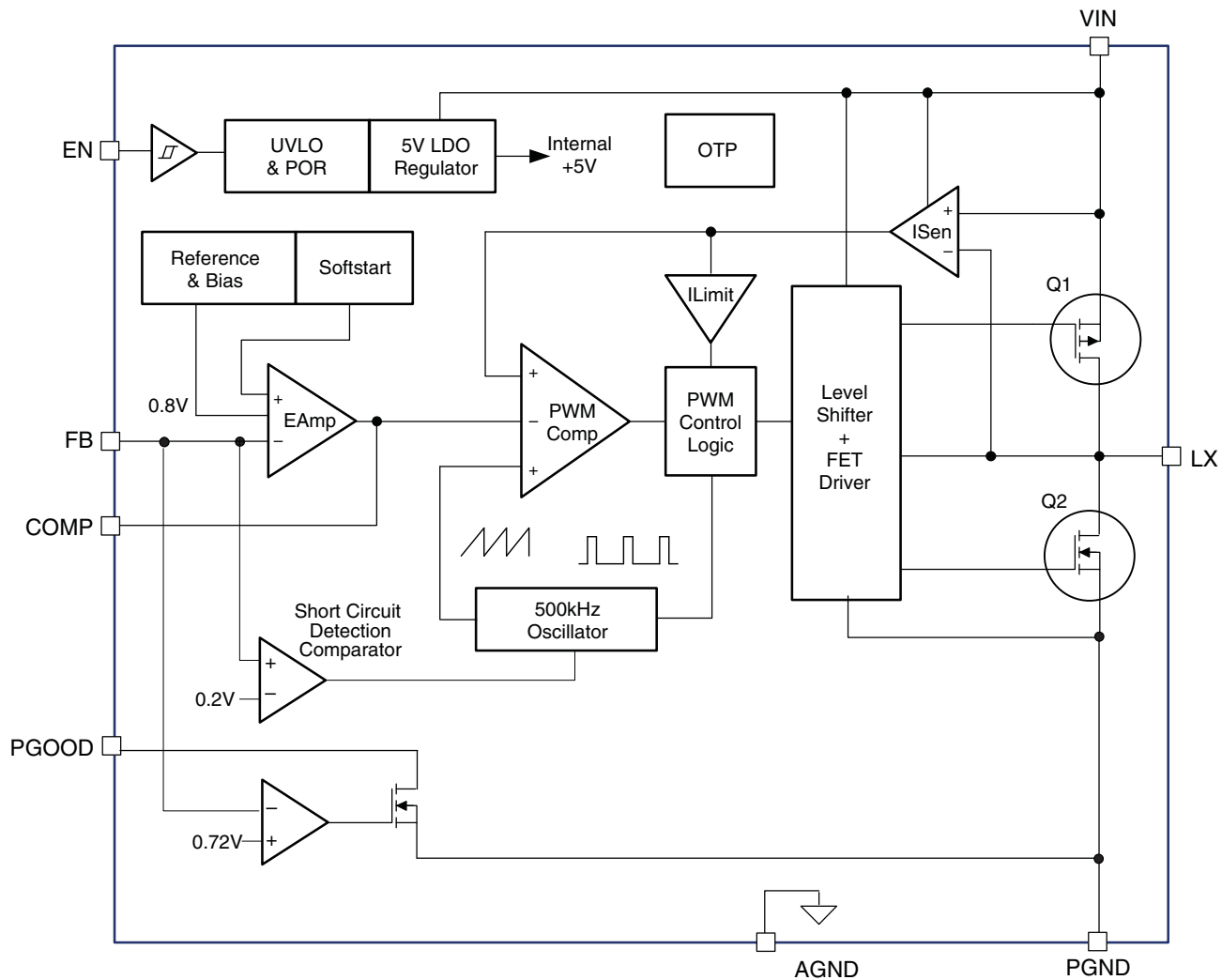

## Absolute Maximum Ratings

Exceeding the Absolute Maximum ratings may damage the device.

Parameter	Rating
Supply Voltage ( $V_{IN}$ )	20V
LX to AGND	-0.7V to $V_{IN}+0.3V$
LX to AGND	23V (<50ns)
EN to AGND	-0.3V to $V_{IN}+0.3V$
FB to AGND	-0.3V to 6V
COMP to AGND	-0.3V to 6V
PGND to AGND	-0.3V to +0.3V
Junction Temperature ( $T_J$ )	+150°C
Storage Temperature ( $T_S$ )	-65°C to +150°C
ESD Rating <sup>(1)</sup>	2.0kV

### Note:

1. Devices are inherently ESD sensitive, handling precautions are required. Human body model rating: 1.5kΩ in series with 100pF.

## Recommended Operating Conditions

The device is not guaranteed to operate beyond the Maximum Recommended Operating Conditions.

Parameter	Rating
Supply Voltage ( $V_{IN}$ )	4.5V to 18V
Output Voltage Range	0.8V to $V_{IN}$
Ambient Temperature ( $T_A$ )	-40°C to +85°C
Package Thermal Resistance Exposed Pad SO-8 ( $\theta_{JA}$ ) <sup>(2)</sup>	50°C/W

### Note:

2. The value of  $\theta_{JA}$  is measured with the device mounted on 1-in<sup>2</sup> FR-4 board with 2oz. Copper, in a still air environment with  $T_A = 25^\circ\text{C}$ . The value in any given application depends on the user's specific board design.

## Electrical Characteristics

 $T_A = 25^\circ\text{C}$ ,  $V_{IN} = V_{EN} = 12\text{V}$ ,  $V_{OUT} = 3.3\text{V}$  unless otherwise specified<sup>(3)</sup>

Symbol	Parameter	Conditions	Min.	Typ.	Max.	Units
$V_{IN}$	Supply Voltage		<b>4.5</b>		<b>18</b>	V
$V_{UVLO}$	Input Under-Voltage Lockout Threshold	$V_{IN}$ Rising $V_{IN}$ Falling		<b>4.1</b> <b>3.7</b>		V
$I_{IN}$	Supply Current (Quiescent)	$I_{OUT} = 0$ , $V_{FB} = 1.2\text{V}$ , $V_{EN} > 1.2\text{V}$		<b>1.6</b>	<b>2.5</b>	mA
$I_{OFF}$	Shutdown Supply Current	$V_{EN} = 0\text{V}$		<b>1.0</b>	<b>10</b>	$\mu\text{A}$
$V_{FB}$	Feedback Voltage	$T_A = 25^\circ\text{C}$	0.788	0.8	0.812	V
	Load Regulation			0.5		%
	Line Regulation			1.0		%
$I_{FB}$	Feedback Voltage Input Current				200	nA
<b>ENABLE</b>						
$V_{EN}$	EN Input Threshold	Off Threshold On Threshold	<b>2</b>		<b>0.6</b>	V
$V_{HYS}$	EN Input Hysteresis			<b>100</b>		mV
<b>MODULATOR</b>						
$f_O$	Frequency		400	500	600	kHz
$D_{MAX}$	Maximum Duty Cycle		100			%
$T_{on\_min}$	Minimum On Time			150		ns
$G_{VEA}$	Error Amplifier Voltage Gain			500		V/V
$G_{EA}$	Error Amplifier Transconductance			200		$\mu\text{A/V}$
<b>PROTECTION</b>						
$I_{LIM}$	Current Limit		5.8	6.5		A
	Over-Temperature Shutdown Limit	$T_J$ Rising $T_J$ Falling		150 100		$^\circ\text{C}$
$t_{SS}$	Soft Start Interval			3		ms
<b>POWER GOOD</b>						
$V_{OLPG}$	PG LOW Voltage	$I_{OL} = 1\text{mA}$			0.6	V
	PG Leakage				1	$\mu\text{A}$
$V_{PGL}$	PG Threshold Voltage		87	90	92	% $V_O$
	PG Threshold Voltage Hysteresis			3		%
$t_{PG}$	PG Delay Time			128		$\mu\text{s}$
<b>PWM OUTPUT STAGE</b>						
	High-Side Switch On-Resistance	$V_{IN} = 12\text{V}$ $V_{IN} = 5\text{V}$		55 75		$\text{m}\Omega$
	Low-Side Switch On-Resistance	$V_{IN} = 12\text{V}$ $V_{IN} = 5\text{V}$		19 23		$\text{m}\Omega$

**Note:**

 3. Specification in **BOLD** indicate an ambient temperature range of  $-40^\circ\text{C}$  to  $+85^\circ\text{C}$ . These specifications are guaranteed by design.

## Typical Performance Characteristics

Circuit of Figure 1.  $T_A = 25^\circ\text{C}$ ,  $V_{IN} = V_{EN} = 12\text{V}$ ,  $V_{OUT} = 3.3\text{V}$  unless otherwise specified.

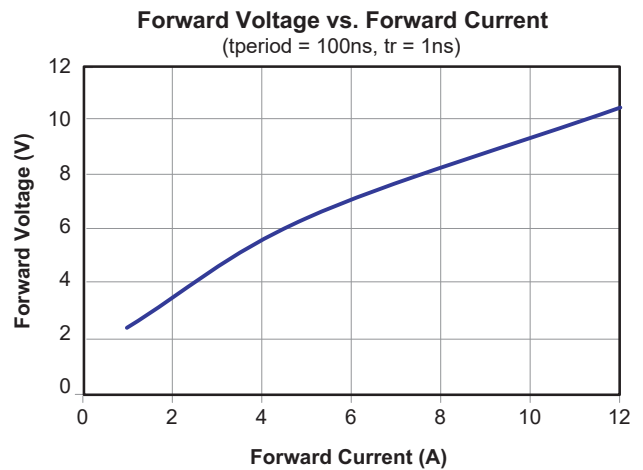
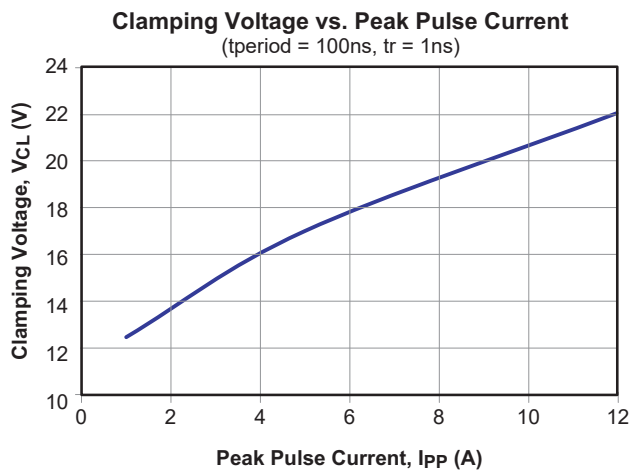

## Efficiency

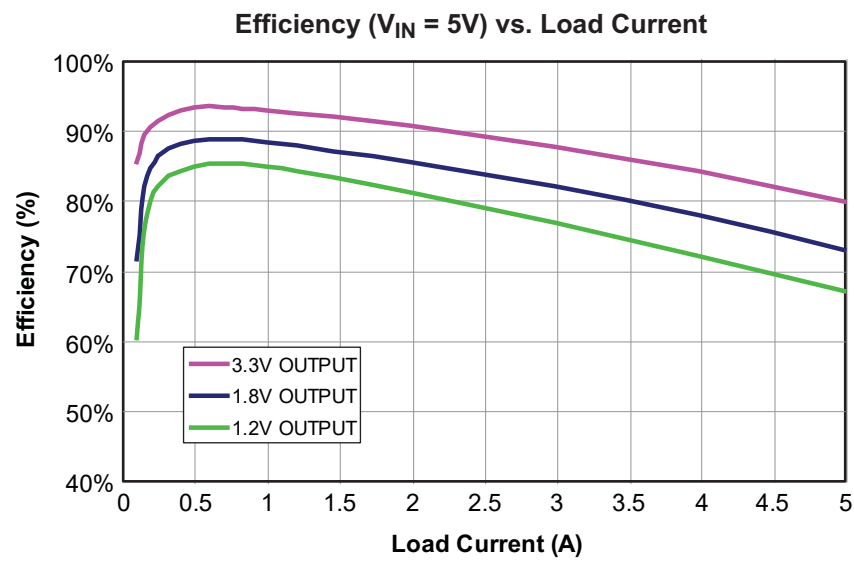
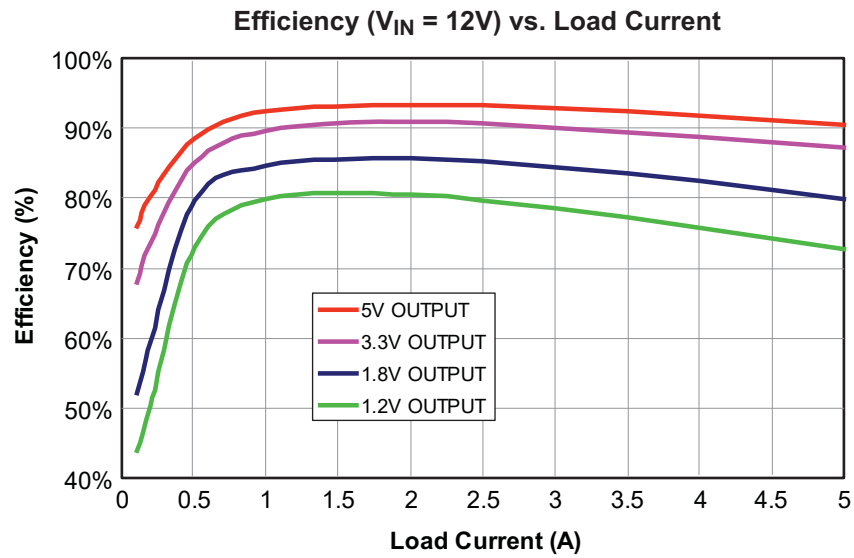

## Detailed Description

The AOZ1037PI-01 is a current-mode step down regulator with integrated high-side PMOS switch and a low-side NMOS switch. It operates from a 4.5V to 18V input voltage range and supplies up to 5A of load current. Features include enable control, Power-On Reset, input under voltage lockout, output over voltage protection, active high power good state, fixed internal soft-start and thermal shut down.

The AOZ1037PI-01 is available in exposed pad SO-8 package.

### Enable and Soft Start

The AOZ1037PI-01 has an internal soft start feature to limit in-rush current and ensure the output voltage ramps up smoothly to regulation voltage. A soft start process begins when the input voltage rises to 4.1V and voltage on EN pin is HIGH. In the soft start process, the output voltage is typically ramped to regulation voltage in 3ms. The 3ms soft start time is set internally.

The EN pin of the AOZ1037PI-01 is active HIGH. Connect the EN pin to  $V_{IN}$  if the enable function is not used. Pulling EN to ground will disable the AOZ1037PI-01. Do not leave it open. The voltage on the EN pin must be above 2V to enable the AOZ1037PI-01. When voltage on the EN pin falls below 0.6V, the AOZ1037PI-01 is disabled. If an application circuit requires the AOZ1037PI-01 to be disabled, an open drain or open collector circuit should be used to interface to the EN pin.

### Power Good

The output of Power-Good is an open drain N-channel MOSFET, which supplies an active high power good stage. A pull-up resistor (R3) should connect this pin to a DC power rail with maximum voltage no higher than 6V. The AOZ1037PI-01 monitors the FB voltage: when FB pin voltage is lower than 90% of the normal voltage, N-channel MOSFET turns on and the Power-Good pin is pulled low, which indicates the power is abnormal.

### Steady-State Operation

Under steady-state conditions, the converter operates in fixed frequency and Continuous-Conduction Mode (CCM).

The AOZ1037PI-01 integrates an internal P-MOSFET as the high-side switch. Inductor current is sensed by amplifying the voltage drop across the drain to source of the high side power MOSFET. Output voltage is divided down by the external voltage divider at the FB pin. The difference of the FB pin voltage and reference is amplified by the internal transconductance error

amplifier. The error voltage, which shows on the COMP pin, is compared against the current signal, which is sum of inductor current signal and ramp compensation signal, at the PWM comparator input. If the current signal is less than the error voltage, the internal high-side switch is on. The inductor current flows from the input through the inductor to the output. When the current signal exceeds the error voltage, the high-side switch is off. The inductor current is freewheeling through the internal low-side N-MOSFET switch to output. The internal adaptive FET driver guarantees no turn on overlap of both high-side and low-side switch.

Comparing with regulators using freewheeling Schottky diodes, the AOZ1037PI-01 uses freewheeling NMOSFET to realize synchronous rectification. It greatly improves the converter efficiency and reduces power loss in the low-side switch.

The AOZ1037PI-01 uses a P-Channel MOSFET as the high-side switch. It saves the bootstrap capacitor normally seen in a circuit which is using an NMOS switch.

### Switching Frequency

The AOZ1037PI-01 switching frequency is fixed and set by an internal oscillator. The practical switching frequency could range from 400 kHz to 600 kHz due to device variation.

### Light Load Mode

The AOZ1037PI-01 includes a Pulse-Skip architecture for Light Load operation, enabling increased efficiency during standby. Under Heavy Loads, the controller operates in a standard Synchronous Mode using the high-side PMOS as control FET and low-side NMOS as synchronous rectifier NMOS. During Light Loads, the controller automatically switches to a Non-Synchronous mode using the high-side PMOS as control FET and the integrated diode as freewheeling rectifier diode.

### Output Voltage Programming

Output voltage can be set by feeding back the output to the FB pin by using a resistor divider network. In the application circuit shown in Figure 1, the resistor divider network includes  $R_1$  and  $R_2$ . Usually, a design is started by picking a fixed  $R_2$  value and calculating the required  $R_1$  with equation below:

Some standard value of  $R_1$ ,  $R_2$  and most used output voltage values are listed in Table 1.

$$V_O = 0.8 \times \left( 1 + \frac{R_1}{R_2} \right)$$

Table 1.

V <sub>O</sub> (V)	R <sub>1</sub> (kΩ)	R <sub>2</sub> (kΩ)
0.8	1.0	Open
1.2	4.99	10
1.5	10	11.5
1.8	12.7	10.2
2.5	21.5	10
3.3	31.1	10
5.0	52.3	10

The combination of R<sub>1</sub> and R<sub>2</sub> should be large enough to avoid drawing excessive current from the output, which will cause power loss.

## Protection Features

The AOZ1037PI-01 has multiple protection features to prevent system circuit damage under abnormal conditions.

### Over Current Protection (OCP)

The sensed inductor current signal is also used for over current protection. Since the AOZ1037PI-01 employs peak current mode control, the COMP pin voltage is proportional to the peak inductor current. The COMP pin voltage is limited to be between 0.4V and 2.5V internally. The peak inductor current is automatically limited cycle by cycle.

When the output is shorted to ground under fault conditions, the inductor current decays very slow during a switching cycle because of V<sub>O</sub> = 0V. To prevent catastrophic failure, a secondary current limit is designed inside the AOZ1037PI-01. The measured inductor current is compared against a preset voltage which represents the current limit. When the output current is more than current limit, the high side switch will be turned off and EN pin will be pulled down. The converter will initiate a soft start once the over-current condition disappears.

### Power-On Reset (POR)

A power-on reset circuit monitors the input voltage. When the input voltage exceeds 4.1V, the converter starts

operation. When input voltage falls below 3.7V, the converter will be shut down.

### Thermal Protection

An internal temperature sensor monitors the junction temperature. It shuts down the internal control circuit and high side PMOS if the junction temperature exceeds 150°C. The regulator will restart automatically under the control of soft-start circuit when the junction temperature decreases to 100°C.

## Application Information

The basic AOZ1037PI-01 application circuit is show in Figure 1. Component selection is explained below.

### Input Capacitor

The input capacitor must be connected to the V<sub>IN</sub> pin and PGND pin of AOZ1037PI-01 to maintain steady input voltage and filter out the pulsing input current. The voltage rating of input capacitor must be greater than maximum input voltage plus ripple voltage.

The input ripple voltage can be approximated by equation below:

$$\Delta V_{IN} = \frac{I_O}{f \times C_{IN}} \times \left( 1 - \frac{V_O}{V_{IN}} \right) \times \frac{V_O}{V_{IN}}$$

Since the input current is discontinuous in a buck converter, the current stress on the input capacitor is another concern when selecting the capacitor. For a buck circuit, the RMS value of input capacitor current can be calculated by:

$$I_{CIN\_RMS} = I_O \times \sqrt{\frac{V_O}{V_{IN}} \left( 1 - \frac{V_O}{V_{IN}} \right)}$$

if we let *m* equal the conversion ratio:

$$\frac{V_O}{V_{IN}} = m$$

The relationship between the input capacitor RMS current and voltage conversion ratio is calculated and shown in Figure 2 below. It can be seen that when V<sub>O</sub> is half of V<sub>IN</sub>, C<sub>IN</sub> is under the worst current stress. The worst current stress on C<sub>IN</sub> is 0.5 x I<sub>O</sub>.



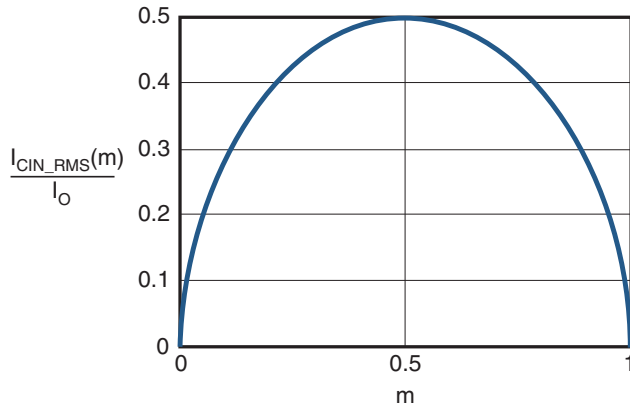

Figure 2.  $I_{CIN}$  vs. Voltage Conversion Ratio

For reliable operation and best performance, the input capacitors must have current rating higher than  $I_{CIN\_RMS}$  at worst operating conditions. Ceramic capacitors are preferred for input capacitors because of their low ESR and high current rating. Depending on the application circuits, other low ESR tantalum capacitor may also be used. When selecting ceramic capacitors, X5R or X7R type dielectric ceramic capacitors should be used for their better temperature and voltage characteristics. Note that the ripple current rating from capacitor manufactures are based on certain amount of life time. Further de-rating may be necessary in practical design.

### Inductor

The inductor is used to supply constant current to output when it is driven by a switching voltage. For given input and output voltage, inductance and switching frequency together decide the inductor ripple current, which is:

$$\Delta I_L = \frac{V_O}{f \times L} \times \left(1 - \frac{V_O}{V_{IN}}\right)$$

The peak inductor current is:

$$I_{Lpeak} = I_O + \frac{\Delta I_L}{2}$$

High inductance gives low inductor ripple current but requires larger size inductor to avoid saturation. Low ripple current reduces inductor core losses. It also reduces RMS current through inductor and switches, which results in less conduction loss. Usually, peak to

peak ripple current on inductor is designed to be 20% to 30% of output current.

When selecting the inductor, make sure it is able to handle the peak current without saturation even at the highest operating temperature.

The inductor takes the highest current in a buck circuit. The conduction loss on inductor need to be checked for thermal and efficiency requirements.

Surface mount inductors in different shape and styles are available from Coilcraft, Elytone and Murata. Shielded inductors are small and radiate less EMI noise. But they cost more than unshielded inductors. The choice depends on EMI requirement, price and size.

### Output Capacitor

The output capacitor is selected based on the DC output voltage rating, output ripple voltage specification and ripple current rating.

The selected output capacitor must have a higher rated voltage specification than the maximum desired output voltage including ripple. De-rating needs to be considered for long term reliability.

Output ripple voltage specification is another important factor for selecting the output capacitor. In a buck converter circuit, output ripple voltage is determined by inductor value, switching frequency, output capacitor value and ESR. It can be calculated by the equation below:

$$\Delta V_O = \Delta I_L \times \left(ESR_{CO} + \frac{1}{8 \times f \times C_O}\right)$$

where,

$C_O$  is output capacitor value, and

$ESR_{CO}$  is the equivalent series resistance of the output capacitor.

When low ESR ceramic capacitor is used as output capacitor, the impedance of the capacitor at the switching frequency dominates. Output ripple is mainly caused by capacitor value and inductor ripple current. The output ripple voltage calculation can be simplified to:

$$\Delta V_O = \Delta I_L \times \frac{1}{8 \times f \times C_O}$$

If the impedance of ESR at switching frequency dominates, the output ripple voltage is mainly decided by capacitor ESR and inductor ripple current. The output ripple voltage calculation can be further simplified to:

$$\Delta V_O = \Delta I_L \times ESR_{CO}$$

For lower output ripple voltage across the entire operating temperature range, X5R or X7R dielectric type of ceramic, or other low ESR tantalum are recommended to be used as output capacitors.

In a buck converter, output capacitor current is continuous. The RMS current of output capacitor is decided by the peak to peak inductor ripple current. It can be calculated by:

$$I_{CO\_RMS} = \frac{\Delta I_L}{\sqrt{12}}$$

Usually, the ripple current rating of the output capacitor is a smaller issue because of the low current stress. When the buck inductor is selected to be very small and inductor ripple current is high, output capacitor could be overstressed.

### External Schottky Diode for High Input Operation

When  $V_{IN}$  is higher than 16V, an external 1A schottky diode is required between LX and PGND for proper operation.

### Loop Compensation

The AOZ1037PI-01 employs peak current mode control for easy use and fast transient response. Peak current mode control eliminates the double pole effect of the output L&C filter. It greatly simplifies the compensation loop design.

With peak current mode control, the buck power stage can be simplified to be a one-pole and one-zero system in frequency domain. The pole is dominant pole can be calculated by:

$$f_{P1} = \frac{1}{2\pi \times C_O \times R_L}$$

The zero is a ESR zero due to output capacitor and its ESR. It is can be calculated by:

$$f_{Z1} = \frac{1}{2\pi \times C_O \times ESR_{CO}}$$

where;

$C_O$  is the output filter capacitor,

$R_L$  is load resistor value, and

$ESR_{CO}$  is the equivalent series resistance of output capacitor.

The compensation design is actually to shape the converter control loop transfer function to get desired gain and phase. Several different types of compensation network can be used for the AOZ1037PI-01. For most cases, a series capacitor and resistor network connected to the COMP pin sets the pole-zero and is adequate for a stable high-bandwidth control loop.

In the AOZ1037PI-01, FB pin and COMP pin are the inverting input and the output of internal error amplifier. A series R and C compensation network connected to COMP provides one pole and one zero. The pole is:

$$f_{P2} = \frac{G_{EA}}{2\pi \times C_2 \times G_{VEA}}$$

where;

$G_{EA}$  is the error amplifier transconductance, which is  $200 \times 10^{-6} A/V$ ,

$G_{VEA}$  is the error amplifier voltage gain, which is 500 V/V, and

$C_2$  is the compensation capacitor in Figure 1.

The zero given by the external compensation network, capacitor  $C_2$  and resistor  $R_3$ , is located at:

$$f_{Z2} = \frac{1}{2\pi \times C_2 \times R_3}$$

To design the compensation circuit, a target crossover frequency  $f_C$  for close loop must be selected. The system crossover frequency is where control loop has unity gain. The crossover is the also called the converter bandwidth. Generally a higher bandwidth means faster response to load transient. However, the bandwidth should not be too high because of system stability concern. When designing the compensation loop, converter stability under all line and load condition must be considered.

Usually, it is recommended to set the bandwidth to be equal or less than 1/10 of switching frequency. The AOZ1037PI-01 operates at a frequency range from 400kHz to 600kHz. It is recommended to choose a crossover frequency equal or less than 40kHz.

$$f_C = 40kHz$$

The strategy for choosing  $R_C$  and  $C_C$  is to set the cross over frequency with  $R_C$  and set the compensator zero with  $C_C$ . Using selected crossover frequency,  $f_C$ , to calculate  $R_C$ :

where;

$f_C$  is the desired crossover frequency. For best performance,  $f_C$  is set to be about 1/10 of the switching frequency;

$V_{FB}$  is 0.8V,

$G_{EA}$  is the error amplifier transconductance, which is  $200 \times 10^{-6}$  A/V, and

$G_{CS}$  is the current sense circuit transconductance, which is 6.68 A/V

The compensation capacitor  $C_C$  and resistor  $R_C$  together make a zero. This zero is put somewhere close to the dominate pole  $f_{p1}$  but lower than 1/5 of selected crossover frequency.  $C_2$  can be selected by:

$$C_C = \frac{1.5}{2\pi \times R_3 \times f_{p1}}$$

The above equation can be simplified to:

$$C_C = \frac{C_O \times R_L}{R_3}$$

An easy-to-use application software which helps to design and simulate the compensation loop can be found at [www.aosmd.com](http://www.aosmd.com).

## Thermal Management and Layout Consideration

In the AOZ1037PI-01 buck regulator circuit, high pulsing current flows through two circuit loops. The first loop starts from the input capacitors, to the  $V_{IN}$  pin, to the LX pins, to the filter inductor, to the output capacitor and load, and then return to the input capacitor through ground. Current flows in the first loop when the high side switch is on. The second loop starts from inductor, to the output capacitors and load, to the low-side NMOSFET. Current flows in the second loop when the low-side NMOSFET is on.

In PCB layout, minimizing the two loops area reduces the noise of this circuit and improves efficiency. A ground plane is strongly recommended to connect input capacitor, output capacitor, and PGND pin of the AOZ1037PI-01.

In the AOZ1037PI-01 buck regulator circuit, the major power dissipating components are the AOZ1037PI-01 and the output inductor. The total power dissipation of converter circuit can be measured by input power minus output power.

$$P_{total\_loss} = V_{IN} \times I_{IN} - V_O \times I_O$$

The power dissipation of inductor can be approximately calculated by output current and DCR of inductor.

$$P_{inductor\_loss} = I_O^2 \times R_{inductor} \times 1.1$$

The actual junction temperature can be calculated with power dissipation in the AOZ1037PI-01 and thermal impedance from junction to ambient.

$$T_{junction} = (P_{total\_loss} - P_{inductor\_loss}) \times \Theta_{JA}$$

The maximum junction temperature of AOZ1037PI-01 is  $150^\circ\text{C}$ , which limits the maximum load current capability. Please see the thermal de-rating curves for maximum load current of the AOZ1037PI-01 under different ambient temperature.

The thermal performance of the AOZ1037PI-01 is strongly affected by the PCB layout. Extra care should be taken by users during design process to ensure that the IC will operate under the recommended environmental conditions.

The AOZ1037PI-01 is an exposed pad SO-8 package. Layout tips are listed below for the best electric and thermal performance.

1. The exposed pad LX pins are connected to internal PFET and NFET drains. Connect a large copper plane to the LX pins to help thermal dissipation.
2. Do not use thermal relief connection to the  $V_{IN}$  and the PGND pin. Pour a maximized copper area to the PGND pin and the VIN pin to help thermal dissipation.
3. Input capacitor should be connected as close as possible to the  $V_{IN}$  pin and the PGND pin to reduce the LX voltage over-shoot. This is especially important for  $V_{IN} > 16\text{V}$ .
4. A ground plane is suggested. If a ground plane is not used, separate PGND from AGND and connect them only at one point to avoid the PGND pin noise coupling to the AGND pin.
5. Make the current trace from the LX pins to L to  $C_O$  to the PGND as short as possible.
6. Pour copper plane on all unused board area and connect it to stable DC nodes, like  $V_{IN}$ , GND or  $V_{OUT}$ .

Package Dimensions, SO-8 EP1

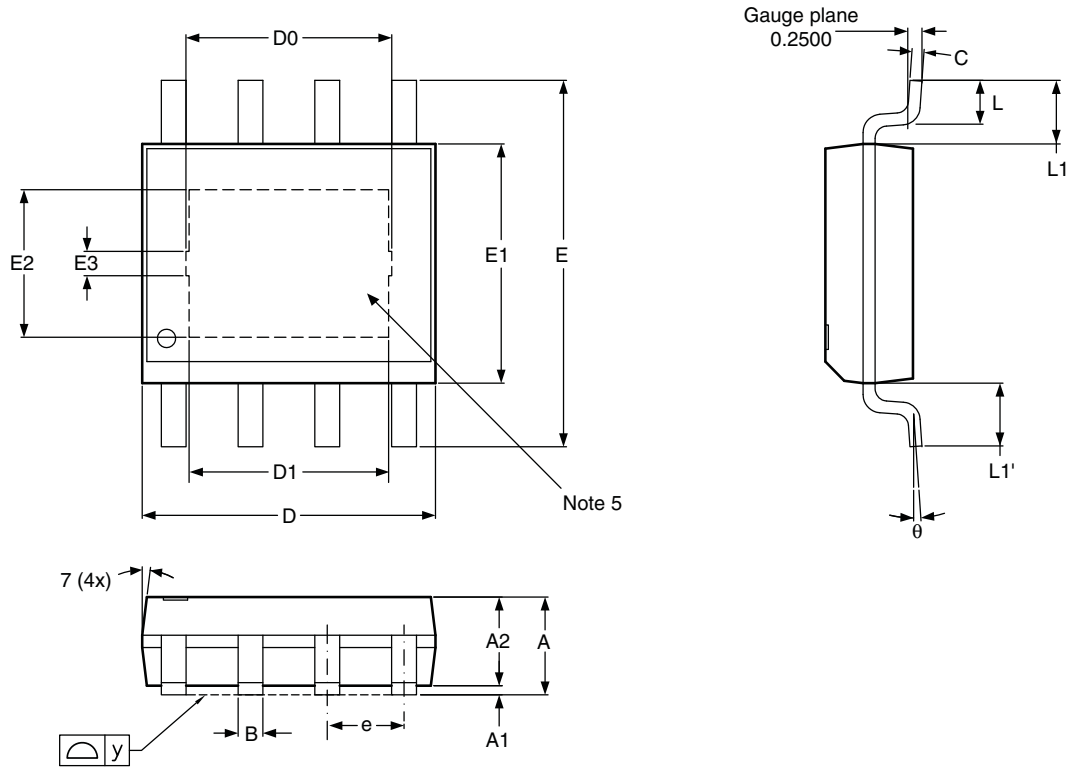

RECOMMENDED LAND PATTERN

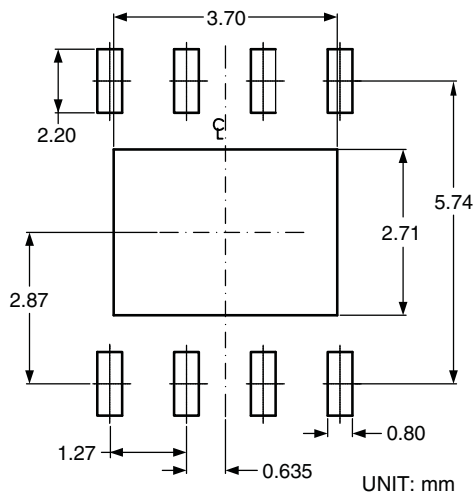

Dimensions in millimeters

Symbols	Min.	Nom.	Max.
A	1.40	1.55	1.70
A1	0.00	0.05	0.10
A2	1.40	1.50	1.60
B	0.31	0.406	0.51
C	0.17	—	0.25
D	4.80	4.96	5.00
D0	3.20	3.40	3.60
D1	3.10	3.30	3.50
E	5.80	6.00	6.20
e	—	1.27	—
E1	3.80	3.90	4.00
E2	2.21	2.41	2.61
E3	0.40 REF		
L	0.40	0.95	1.27
y	—	—	0.10
θ	0	3	8
L1-L1'	—	0.04	0.12
L1	1.04 REF		

Dimensions in inches

Symbols	Min.	Nom.	Max.
A	0.055	0.061	0.067
A1	0.000	0.002	0.004
A2	0.055	0.059	0.063
B	0.012	0.016	0.020
C	0.007	—	0.010
D	0.189	0.195	0.197
D0	0.126	0.134	0.142
D1	0.122	0.130	0.138
E	0.228	0.236	0.244
e	—	0.050	—
E1	0.150	0.153	0.157
E2	0.087	0.095	0.103
E3	0.016 REF		
L	0.016	0.037	0.050
y	—	—	0.004
θ	0	3	8
L1-L1'	—	0.002	0.005
L1	0.041 REF		

Notes:

1. Package body sizes exclude mold flash and gate burrs.
2. Dimension L is measured in gauge plane.
3. Tolerance 0.10mm unless otherwise specified.
4. Controlling dimension is millimeter, converted inch dimensions are not necessarily exact.
5. Die pad exposure size is according to lead frame design.
6. Followed from JEDEC MS-012

## Tape and Reel Dimensions

### SO-8 Carrier Tape

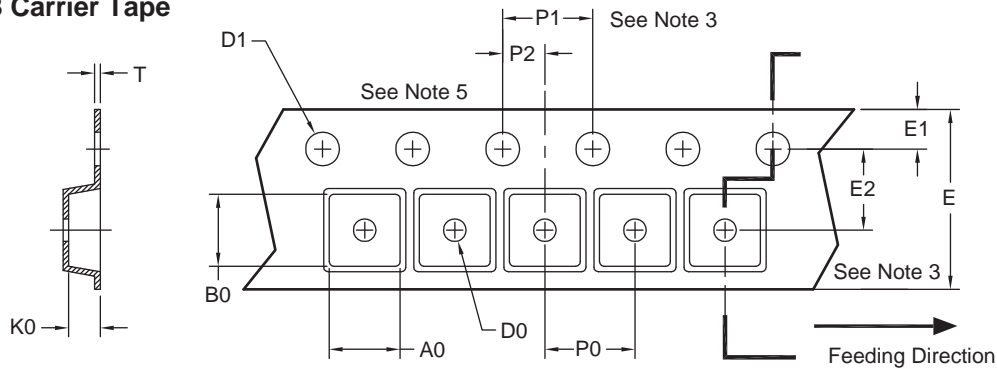

Unit: mm

Package	A0	B0	K0	D0	D1	E	E1	E2	P0	P1	P2	T
SO-8 (12mm)	6.40 ±0.10	5.20 ±0.10	2.10 ±0.10	1.60 ±0.10	1.50 ±0.10	12.00 ±0.10	1.75 ±0.10	5.50 ±0.10	8.00 ±0.10	4.00 ±0.10	2.00 ±0.10	0.25 ±0.10

### SO-8 Reel

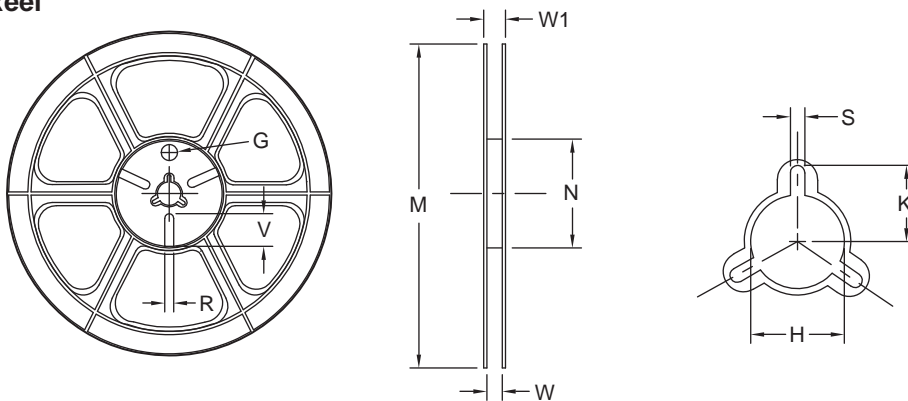

Tape Size	Reel Size	M	N	W	W1	H	K	S	G	R	V
12mm	ø330	ø330.00 ±0.50	ø97.00 ±0.10	13.00 ±0.30	17.40 ±1.00	ø13.00 +0.50/-0.20	10.60	2.00 ±0.50	—	—	—

### SO-8 Tape

Leader/Trailer  
& Orientation

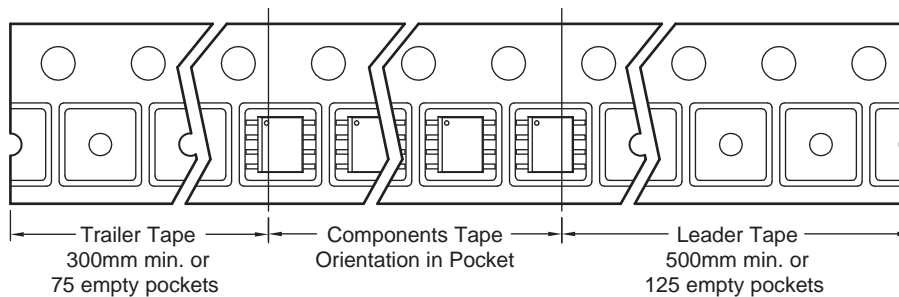

## Part Marking

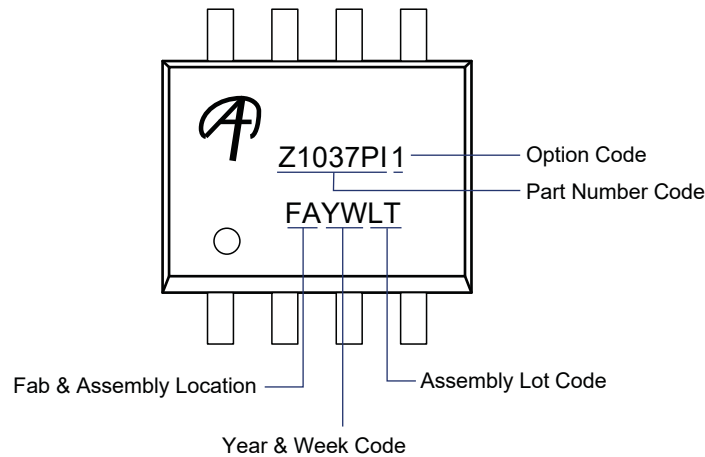

### LEGAL DISCLAIMER

Applications or uses as critical components in life support devices or systems are not authorized. AOS does not assume any liability arising out of such applications or uses of its products. AOS reserves the right to make changes to product specifications without notice. It is the responsibility of the customer to evaluate suitability of the product for their intended application. Customer shall comply with applicable legal requirements, including all applicable export control rules, regulations and limitations.

AOS' products are provided subject to AOS' terms and conditions of sale which are set forth at:

[http://www.aosmd.com/terms and conditions of sale](http://www.aosmd.com/terms_and_conditions_of_sale)

### LIFE SUPPORT POLICY

ALPHA & OMEGA SEMICONDUCTOR PRODUCTS ARE NOT AUTHORIZED FOR USE AS CRITICAL COMPONENTS IN LIFE SUPPORT DEVICES OR SYSTEMS.

As used herein:

1. Life support devices or systems are devices or systems which, (a) are intended for surgical implant into the body or (b) support or sustain life, and (c) whose failure to perform when properly used in accordance with instructions for use provided in the labeling, can be reasonably expected to result in a significant injury of the user.
2. A critical component in any component of a life support, device, or system whose failure to perform can be reasonably expected to cause the failure of the life support device or system, or to affect its safety or effectiveness.