

# IPM-5C Package Outline

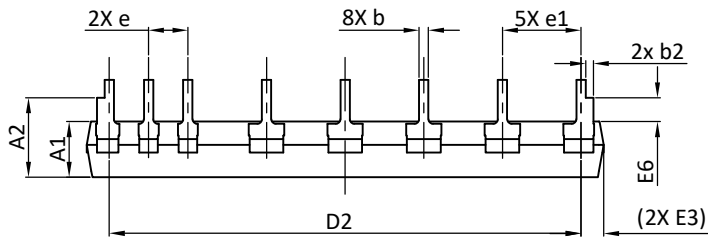

SIDE VIEW

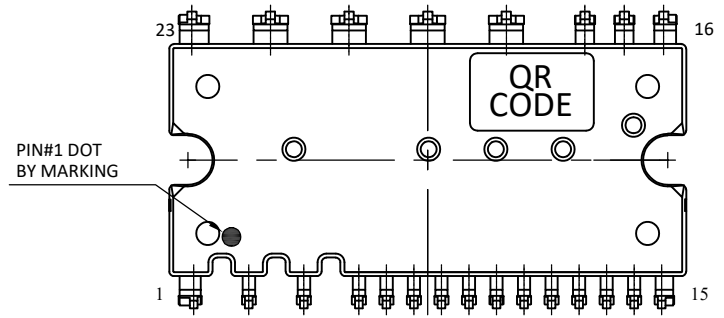

BOTTOM VIEW

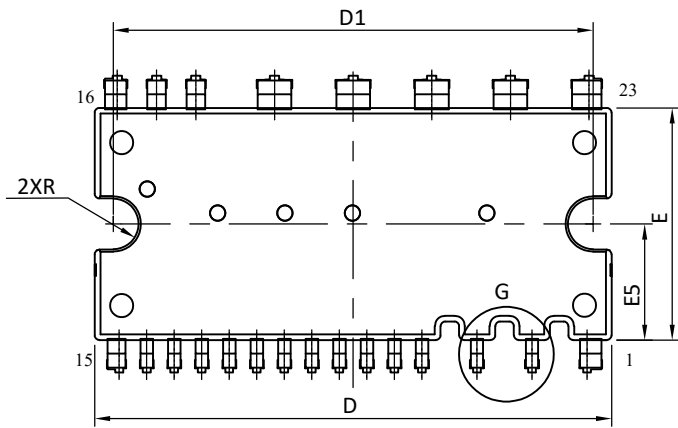

TOP VIEW

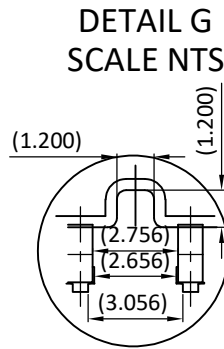

DETAIL G  
SCALE NTS

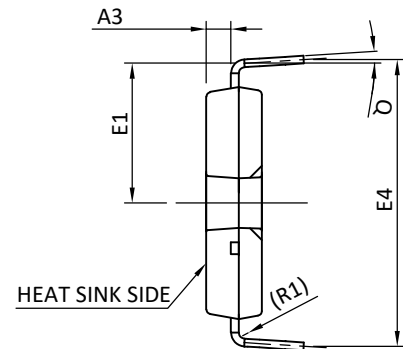

SIDE VIEW

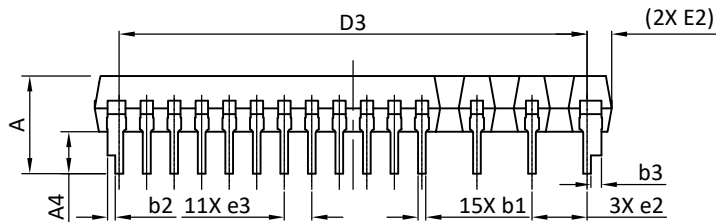

SIDE VIEW

## LAND PATTERN RECOMMENDATIONS

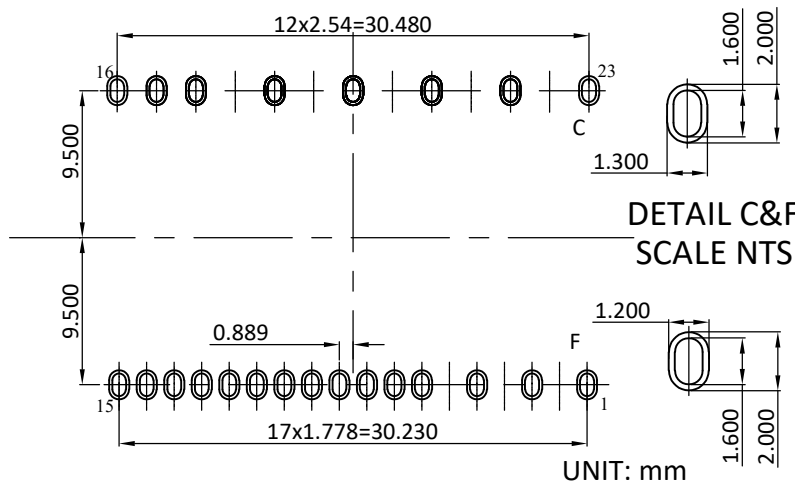

DETAIL C&F  
SCALE NTS

SYMBOLS	DIMENSION IN MILLIMETRES			DIMENSION IN INCHS		
	MIN.	NOM.	MAX.	MIN.	NOM.	MAX.
A	5.900	6.300	6.700	0.232	0.248	0.264
A1	3.400	3.600	3.800	0.134	0.142	0.150
A2	4.700	5.100	5.500	0.185	0.201	0.217
A3	1.500	1.600	1.700	0.059	0.063	0.067
A4	2.500	2.700	2.900	0.098	0.106	0.114
B	0.400	0.500	0.600	0.016	0.020	0.024
b	0.500	0.600	0.700	0.020	0.024	0.028
b1	0.400	0.500	0.600	0.016	0.020	0.024
b2	0.400	0.500	0.600	0.016	0.020	0.024
b3	0.600	0.700	0.800	0.024	0.028	0.031
D	33.100	33.400	33.700	1.303	1.315	1.327
D1	30.800	31.000	31.200	1.213	1.220	1.228
D2	30.180	30.480	30.780	1.188	1.200	1.212
D3	29.930	30.230	30.530	1.178	1.190	1.202
E	14.700	15.000	15.300	0.579	0.591	0.602
E1	8.600	9.000	9.400	0.339	0.354	0.370
E2	1.600REF			0.063REF		
E3	1.500REF			0.059REF		
E4	18.120	18.520	18.920	0.713	0.729	0.745
E5	7.300	7.500	7.700	0.287	0.295	0.303
E6	1.100	1.500	1.900	0.043	0.059	0.075
e	2.340	2.540	2.740	0.092	0.100	0.108
e1	4.880	5.080	5.280	0.192	0.200	0.208
e2	3.356	3.556	3.756	0.132	0.140	0.148
e3	1.578	1.778	1.978	0.062	0.070	0.078
R	1.500	1.600	1.700	0.059	0.063	0.067
R1	0.400REF			0.016REF		
Q	2° - 6°			2° - 6°		

## NOTES

1. PACKAGE BODY SIZES EXCLUDE MOLD FLASH AND GATE BURRS, MOLD FLASH SHOULD BE LESS THAN 6 MIL.
2. TOLERANCE 0.100 MILLIMETERS UNLESS OTHERWISE SPECIFIED.
3. CONTROLLING DIMENSION IS MILLIMETER, CONVERTED INCH DIMENSIONS ARE NOT NECESSARILY EXACT.
4. ( ) IS REFERENCE.