

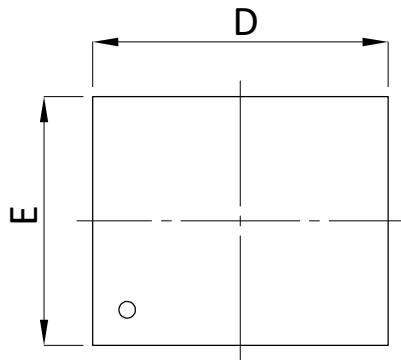

## AlphaDFN1.9x1.6\_6 PACKAGE OUTLINE

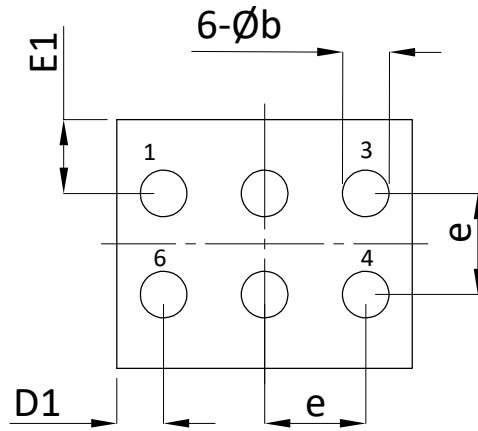

FRONT VIEW



BOTTOM VIEW

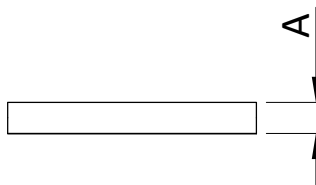

SIDE VIEW

### RECOMMENDED LANDPATTERN

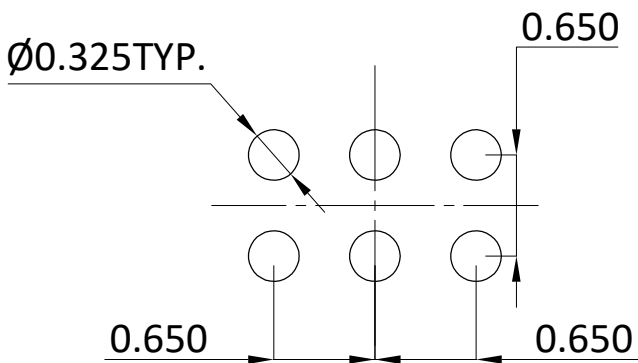

SYMBOLS	DIMENSIONS IN MM			DIMENSIONS IN INCH		
	MIN.	NOM.	MAX.	MIN.	NOM.	MAX.
A	---	---	0.130	---	---	0.005
b	0.275	0.300	0.325	0.011	0.012	0.013
D	1.870	1.900	1.930	0.074	0.075	0.076
D1	0.270	0.300	0.330	0.011	0.012	0.013
E	1.570	1.600	1.630	0.062	0.063	0.064
E1	0.445	0.475	0.505	0.018	0.019	0.020
e	0.65BSC.			0.026BSC.		

UNIT: mm

**NOTE:**

1. CONTROLLED DIMENSION IS IN MILLIMETER.
2. THE SCRIBE LINE IS NOT INCLUDED IN THE POD.
3. THIS PACKAGE WAS QUALIFIED USING IR REFLOW PROCESS (JEDEC STANDARD). FOR USAGE IN OTHER SOLDERING PROCESSES, PLEASE CONTACT LOCAL AOS REPRESENTATIVES.