

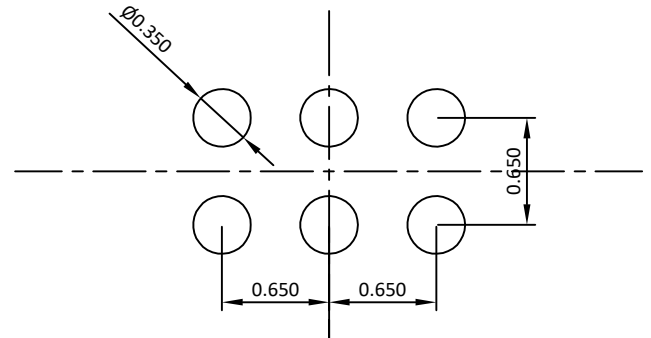

AlphaDFN2.7x1.81A_6 Package Outline

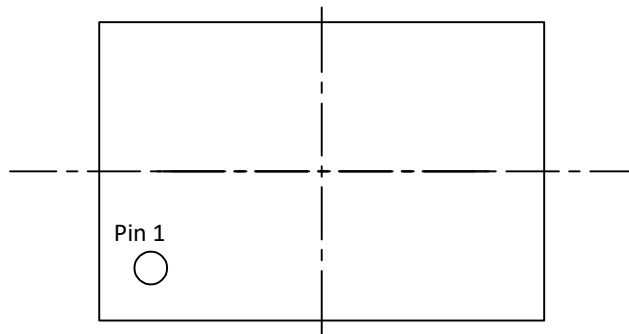
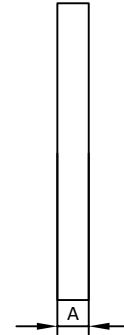
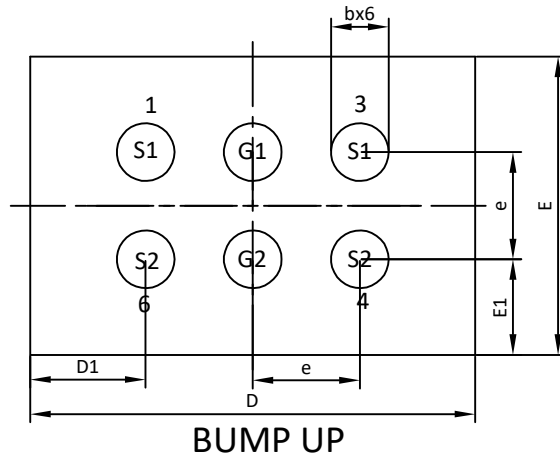

SYMBOLS	DIM. IN MM			DIM. IN INCH		
	MIN.	NOM.	MAX.	MIN.	NOM.	MAX.
A	-----	-----	0.250	-----	-----	0.0098
b	0.250	0.300	0.350	0.0098	0.0118	0.0138
D	2.650	2.700	2.750	0.1043	0.1063	0.1083
D1	0.650	0.700	0.750	0.0256	0.0276	0.0295
E	1.750	1.810	1.850	0.0689	0.0713	0.0728
E1	0.530	0.580	0.630	0.0209	0.0228	0.0248
e	0.650BSC			0.0256BSC		

NOTE:

1. CONTROLLED DIMENSIONS ARE IN MILLIMETERS. CONVERTED INCH DIMENSIONS ARE NOT NECESSARILY EXACT.
2. THE SCRIBBLE LINE IS NOT INCLUDED IN THE POD, IF WITH SCRIBBLE LINE, D AND E DIMENSION WILL PLUS 0.05MM RESPECTIVELY.
3. THIS PACKAGE WAS QUALIFIED USING IR REFLOW PROCESS (JEDEC STANDARD). FOR USAGE IN OTHER SOLDERING PROCESSES, PLEASE CONTACT LOCAL AOS REPRESENTATIVES.