

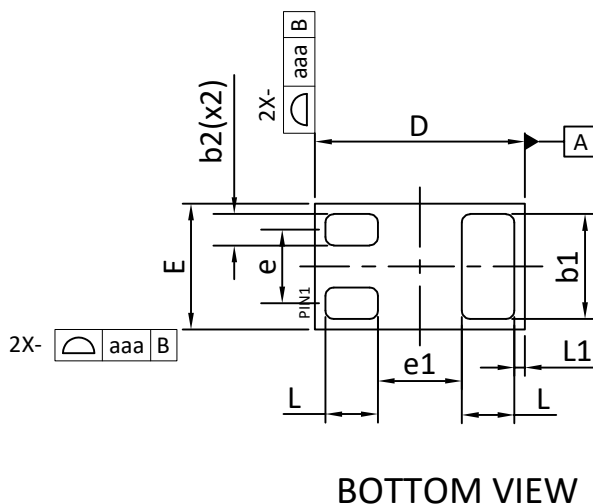

DFN1.0x0.6_3L_EP1_S PACKAGE OUTLINE

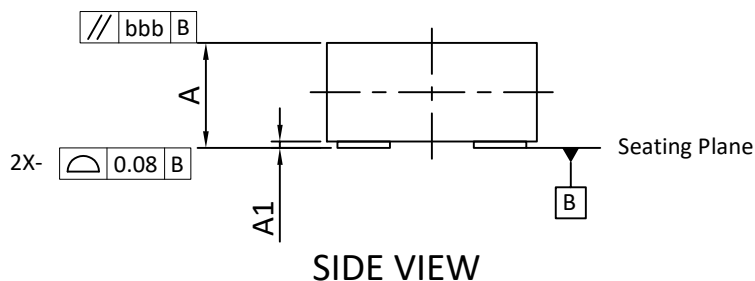

RECOMMENDED LAND PATTERN

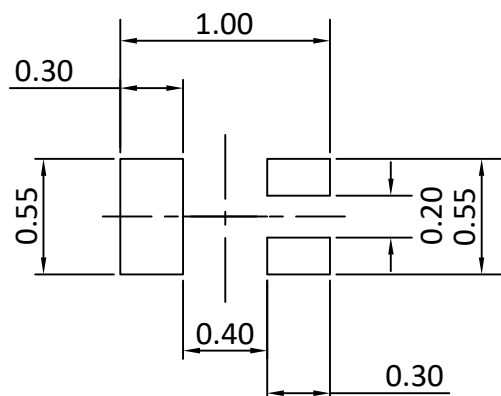

UNIT: mm

SYMBOLS	DIMENSIONS IN MILLIMETERS			DIMENSIONS IN INCHES		
	MIN	NOM	MAX	MIN	NOM	MAX
A	0.47	0.52	0.55	0.019	0.020	0.022
A1	0.00	0.03	0.05	0.000	0.001	0.002
b1	0.45	0.50	0.55	0.018	0.020	0.022
b2	0.10	0.15	0.20	0.004	0.006	0.008
D	0.95	1.00	1.05	0.037	0.039	0.041
E	0.55	0.60	0.65	0.022	0.024	0.026
e	---	0.35	---	---	0.014	---
e1	---	0.40	---	---	0.016	---
L	0.20	0.25	0.30	0.008	0.010	0.012
L1	---	0.05	---	---	0.002	---
aaa	0.15			0.006		
bbb	0.05			0.002		

NOTE

1. ALL DIMENSION ARE IN MILLIMETERS.ANGLES ARE IN DEGREES.
2. COPLANARITY APPLIES TO THE EXPOSED HEAT SINK SLUG AS WELL AS THE TERMINALS.
3. THIS PACKAGE WAS QUALIFIED USING IR REFLOW PROCESS (JEDEC STANDARD). FOR USAGE IN OTHER SOLDERING PROCESSES, PLEASE CONTACT LOCAL AOS REPRESENTATIVES.