

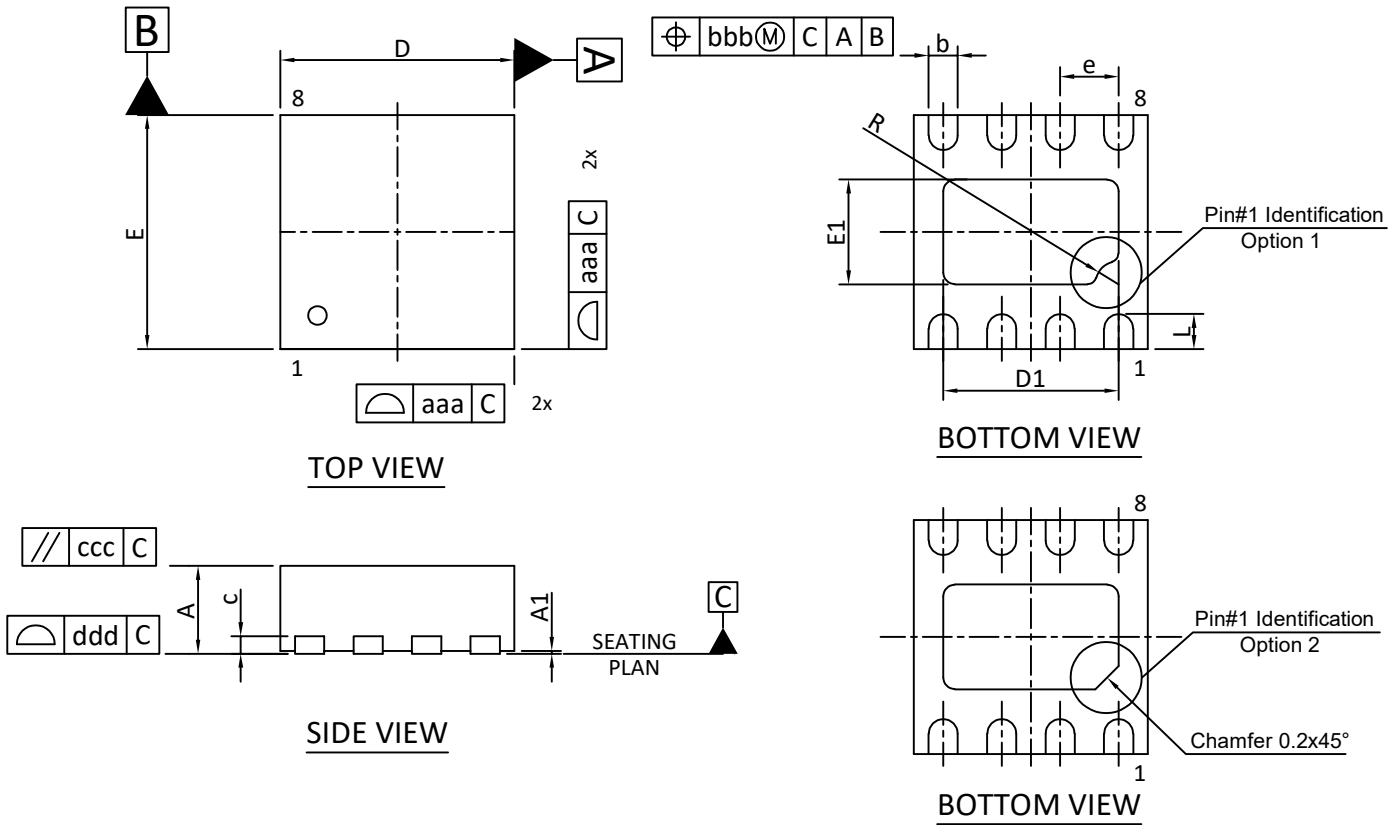

DFN2x2\_8L\_EP1\_S PACKAGE OUTLINE

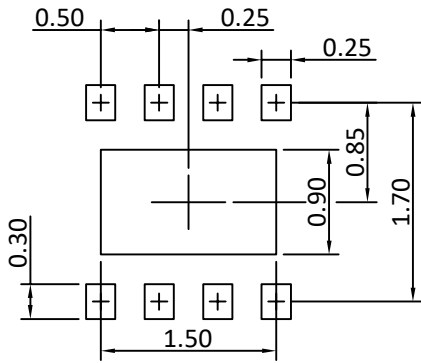

RECOMMENDED LAND PATTERN



UNIT: mm

SYMBOLS	DIM. IN MM			DIM. IN INCH		
	MIN.	NOM.	MAX.	MIN.	NOM.	MAX.
A	0.700	0.750	0.800	0.028	0.030	0.031
A1	0.000	0.020	0.050	0.000	0.001	0.002
b	0.180	0.250	0.300	0.007	0.010	0.012
c	---	0.20Ref	---	---	0.008Ref	---
D	1.900	2.000	2.100	0.075	0.079	0.083
D1	1.350	1.500	1.600	0.053	0.059	0.063
E	1.900	2.000	2.100	0.075	0.079	0.083
E1	0.750	0.900	1.000	0.030	0.035	0.039
e	0.50BSC			0.020BSC		
L	0.200	0.300	0.400	0.008	0.012	0.016
R	0.200			0.008		
aaa	0.150			0.006		
bbb	0.100			0.004		
ccc	0.100			0.004		
ddd	0.080			0.003		

NOTE

- DIMENSIONING AND TOLERANCING CONFORM TO ASME Y14.5M-1994.
- CONTROLLING DIMENSION IS MILLIMETER.  
CONVERTED INCH DIMENSIONS ARE NOT NECESSARILY EXACT.
- DIMENSION b APPLIES TO METALLIZED TERMINAL AND IS MEASURED BETWEEN 0.10mm. AND 0.30mm FROM THE TERMINAL TIP. IF THE TERMINAL HAS THE OPTIONAL RADIUS ON THE OTHER END OF THE TERMINAL, THE DIMENSION b SHOULD NOT BE MEASURED IN THAT RADIUS AREA.
- COPLANARITY ddd APPLIES TO THE TERMINALS AND ALL OTHER BOTTOM SURFACE METALLIZATION.