

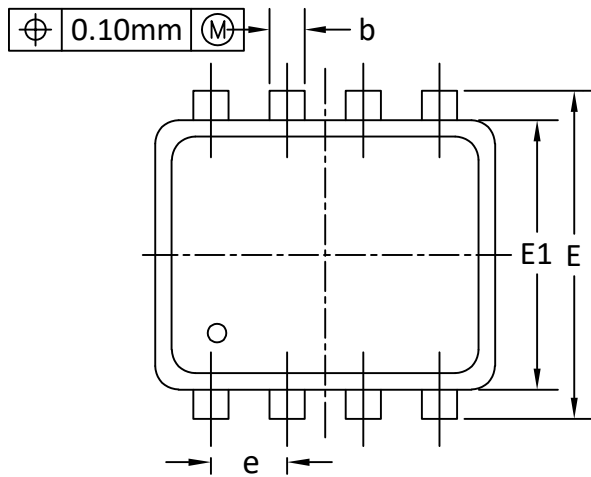

DFN3x3A_8L_NEP_P PACKAGE OUTLINE

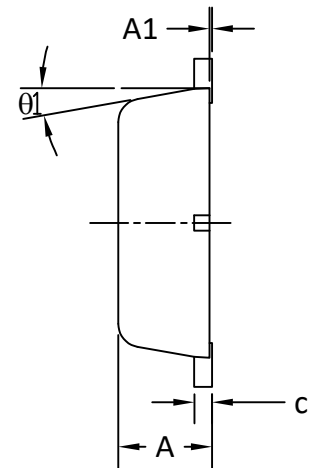

TOP VIEW



SIDE VIEW

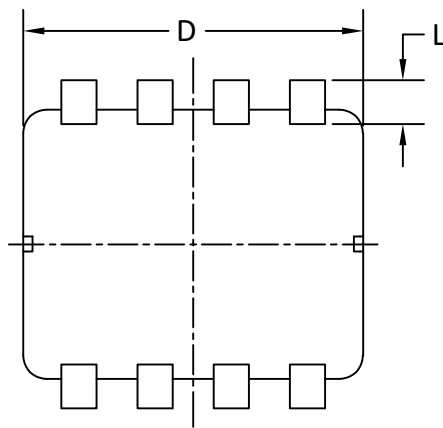

BOTTOM VIEW

RECOMMENDED LAND PATTERN

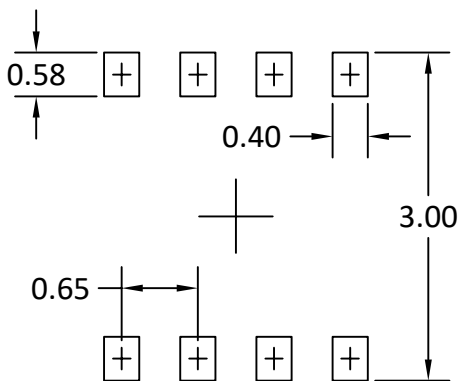

UNIT: mm

SYMBOLS	DIM. IN MM			DIM. IN INCH		
	MIN.	NOM.	MAX.	MIN.	NOM.	MAX.
A	0.700	0.800	0.900	0.028	0.031	0.035
A1	0.000	-	0.050	0.000	-	0.002
b	0.240	0.300	0.350	0.009	0.012	0.014
c	0.080	0.150	0.250	0.003	0.006	0.010
D	2.800	2.900	3.000	0.110	0.114	0.118
E	2.700	2.800	2.900	0.106	0.110	0.114
E1	2.200	2.300	2.400	0.087	0.091	0.095
e	0.65BSC			0.026BSC		
L	0.200	0.380	0.450	0.008	0.015	0.018
θ1	0°	10°	12°	0°	10°	12°

NOTE

1. PACKAGE BODY SIZES EXCLUDE MOLD FLASH AND GATE BURRS.
MOLD FLASH AT THE NON-LEAD SIDES SHOULD BE LESS THAN 6 MIL EACH.
2. CONTROLLING DIMENSION IS MILLIMETER.
CONVERTED INCH DIMENSIONS ARE NOT NECESSARILY EXACT.
3. THIS PACKAGE WAS QUALIFIED USING IR REFLOW PROCESS (JEDEC STANDARD). FOR USAGE IN OTHER SOLDERING PROCESSES, PLEASE CONTACT LOCAL AOS REPRESENTATIVES.