

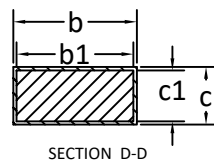

SOT223_4L PACKAGE OUTLINE

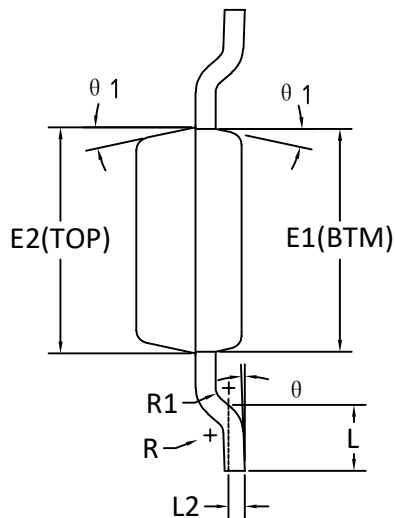

RECOMMENDED LAND PATTERN

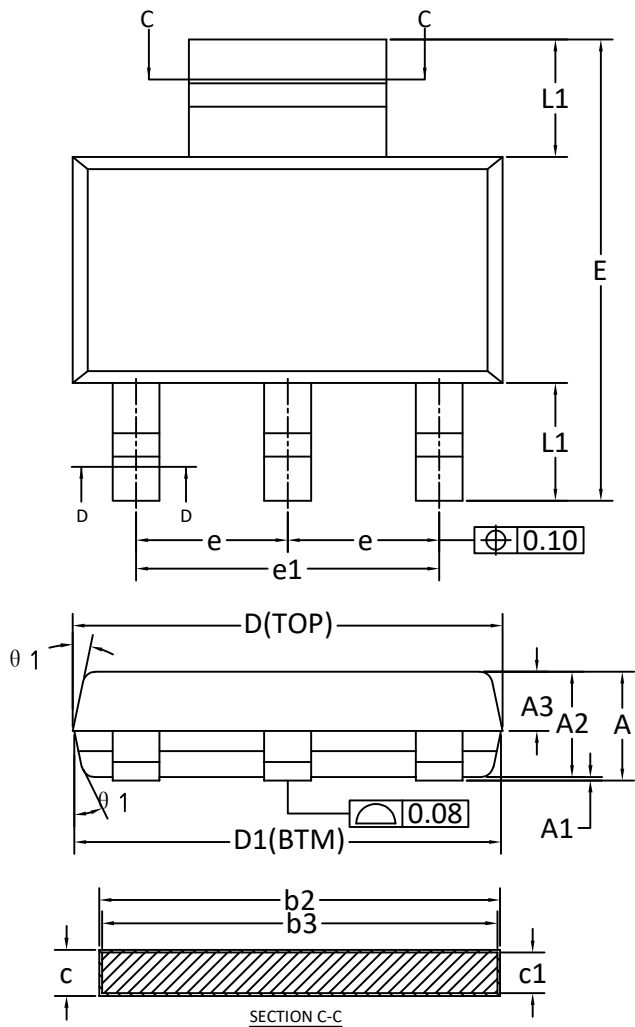
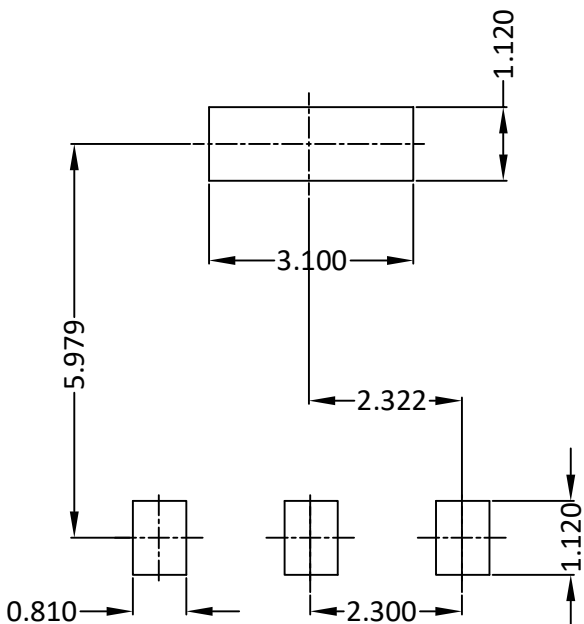

- NOTE
 1. PACKAGE BODY SIZES EXCLUDE MOLD FLASH AND GATE BURRS.
 MOLD FLASH AT THE NON-LEAD SIDES SHOULD BE LESS THAN 6 MILS EACH.
 2. CONTROLLING DIMENSION IS MILLIMETER.
 CONVERTED INCH DIMENSIONS ARE NOT NECESSARILY EXACT.

SYMBOLS	DIM. IN MM			DIM. IN INCH		
	MIN.	NOM.	MAX.	MIN.	NOM.	MAX.
A	----	----	1.80	----	----	0.071
A1	0.02	----	0.10	0.009	----	0.002
A2	1.50	1.600	1.70	0.059	0.063	0.067
A3	0.800	0.900	1.000	0.031	0.035	0.039
b	0.67	----	0.80	0.026	----	0.031
b1	0.66	0.710	0.76	0.026	0.028	0.030
b2	2.96	----	3.09	0.117	----	0.122
b3	2.95	3.000	3.05	0.116	0.118	0.120
c	0.30	----	0.35	0.012	----	0.014
c1	0.290	0.300	0.310	0.011	0.012	0.012
D	6.480	6.530	6.580	0.255	0.257	0.259
D1	6.430	6.480	6.530	0.253	0.255	0.257
E	6.800	----	7.200	0.268	----	0.283
E1	3.300	3.380	3.480	0.130	0.133	0.137
E2	3.330	3.430	3.530	0.131	0.135	0.139
e	2.250	2.300	2.350	0.088	0.091	0.093
e1	4.500	4.600	4.700	0.177	0.181	0.185
L	0.800	1.000	1.200	0.031	0.039	0.047
L1	1.78REF			0.070REF		
L2	0.25BSC			0.010BSC		
R	0.10	----	----	0.004	----	----
R1	0.10	----	----	0.004	----	----
θ	0°	----	8°	0°	----	8°
θ1	10°	12°	14°	10°	12°	14°