

SOT23_6L PACKAGE OUTLINE

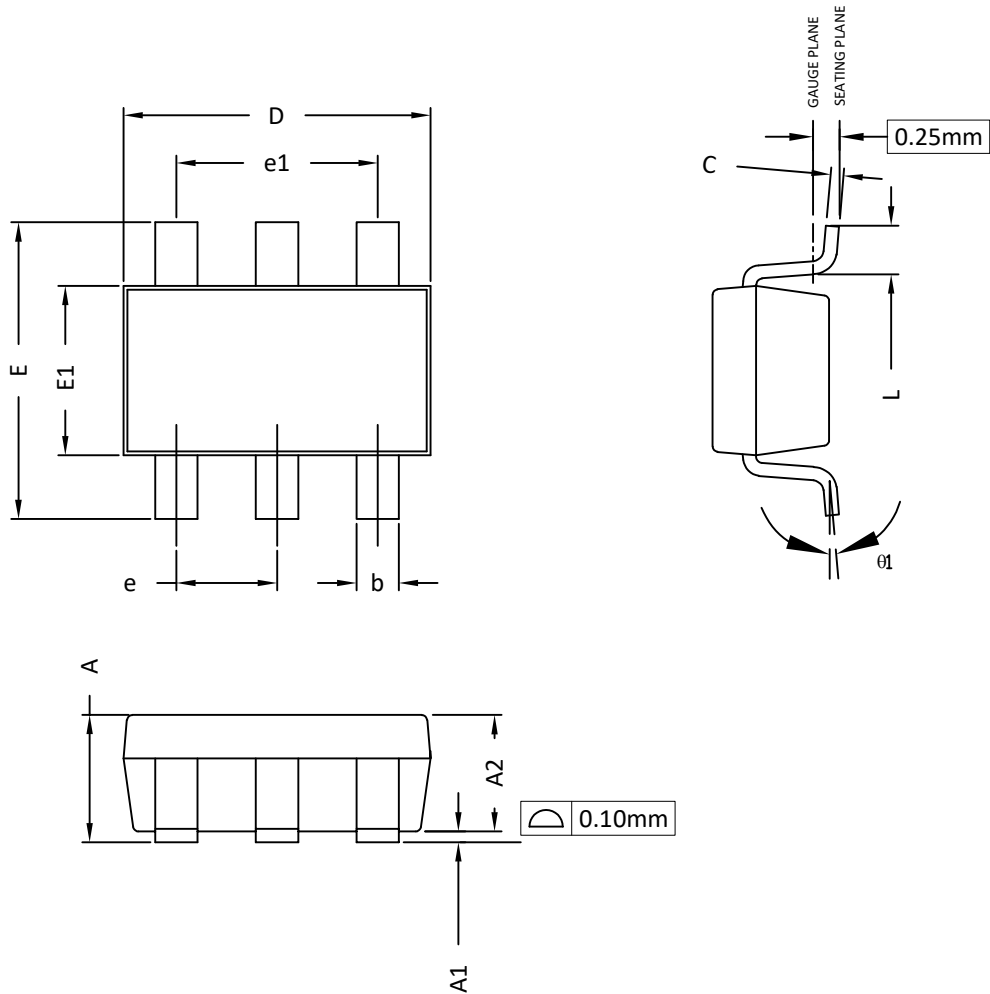

RECOMMENDED LAND PATTERN

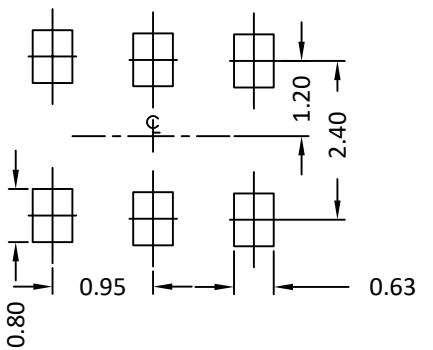

UNIT: mm

SYMBOLS	DIMENSION IN MM			DIMENSION IN INCHES		
	MIN	NOM	MAX	MIN	NOM	MAX
A	0.90	---	1.25	0.035	----	0.049
A1	0.00	---	0.15	0.000	----	0.006
A2	0.70	1.10	1.20	0.028	0.043	0.047
b	0.30	0.40	0.50	0.012	0.016	0.020
c	0.08	0.13	0.20	0.003	0.005	0.008
D	2.70	2.90	3.10	0.106	0.114	0.122
e	0.95 BSC			0.037 BSC		
e1	1.90 BSC			0.075 BSC		
E	2.50	2.80	3.10	0.098	0.110	0.122
E1	1.50	1.60	1.73	0.059	0.063	0.068
L	0.30	---	0.60	0.012	----	0.024
θ1	0°	---	8°	0°	----	8°

NOTE:

1. PACKAGE BODY SIZES EXCLUDE MOLD FLASH AND GATE BURRS.
MOLD FLASH AT THE NON-LEAD SIDES SHOULD BE LESS THAN 5 MILS EACH.
2. DIMENSION "L" IS MEASURED IN GAGE PLANE.
3. TOLERANCE ± 0.100 mm (4 mil) UNLESS OTHERWISE SPECIFIED.
4. FOLLOWED FROM JEDEC MO-178C & MO-193C.
5. CONTROLLING DIMENSIONS IS MILLIMETER.
CONVERTED INCH DIMENSIONS ARE NOT NECESSARILY EXACT.