

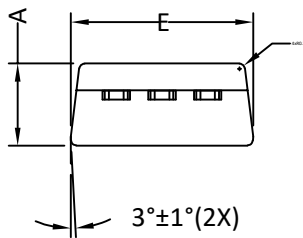

TO262 PACKAGE OUTLINE

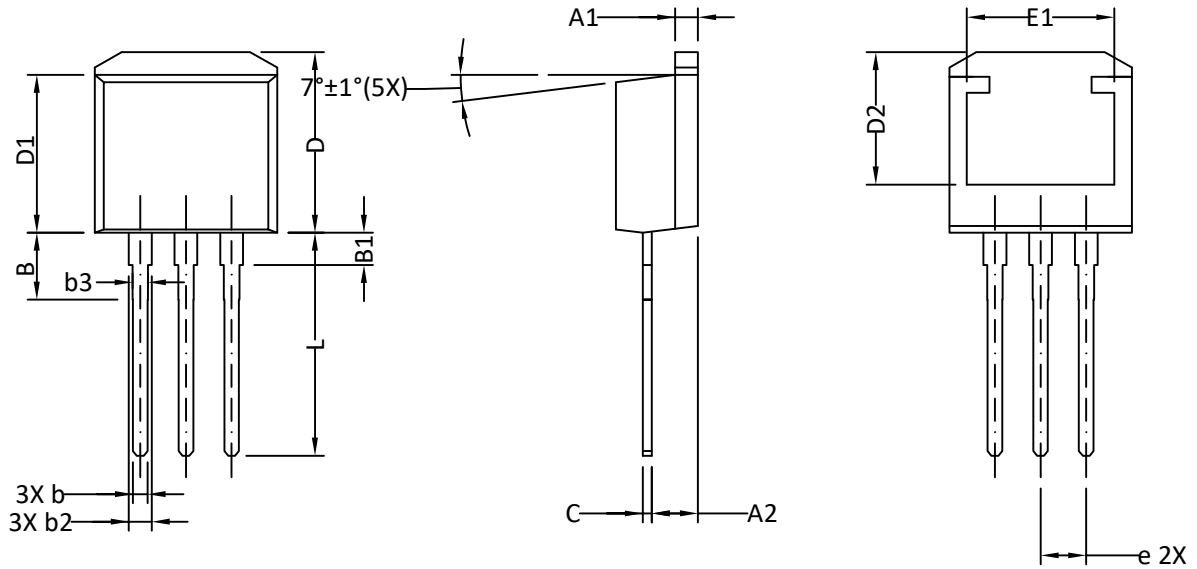

RECOMMENDED LAND PATTERN

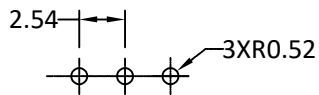

SYMBOLS	DIM. IN MM			DIM. IN INCH		
	MIN.	NOM.	MAX.	MIN.	NOM.	MAX.
A	4.300	4.570	4.720	0.169	0.180	0.186
A1	1.170	1.270	1.370	0.046	0.050	0.054
A2	2.470	2.570	2.670	0.097	0.101	0.105
B	3.550	3.720	3.900	0.140	0.146	0.154
B1	1.650	1.800	2.000	0.065	0.071	0.079
b	0.690	0.813	0.940	0.027	0.032	0.037
b2	1.170	1.270	1.400	0.046	0.050	0.055
b3	0.740	0.860	0.910	0.029	0.034	0.036
c	0.480	0.500	0.600	0.019	0.020	0.024
D	9.800	10.05	10.300	0.386	0.396	0.406
D1	8.640	8.780	9.650	0.340	0.346	0.380
D2	7.120	7.370	7.620	0.280	0.290	0.300
e	2.540			0.100		
E	9.700	10.150	10.540	0.382	0.400	0.415
E1	8.000	8.200	8.400	0.315	0.323	0.331
L	12.270	12.400	13.480	0.483	0.488	0.531

NOTE

1. CONTROLLING DIMENSION IS MILLIMETER.
CONVERTED INCH DIMENSIONS ARE NOT NECESSARILY EXACT.