

## WLCSP2.05x2.01\_16 PACKAGE OUTLINE

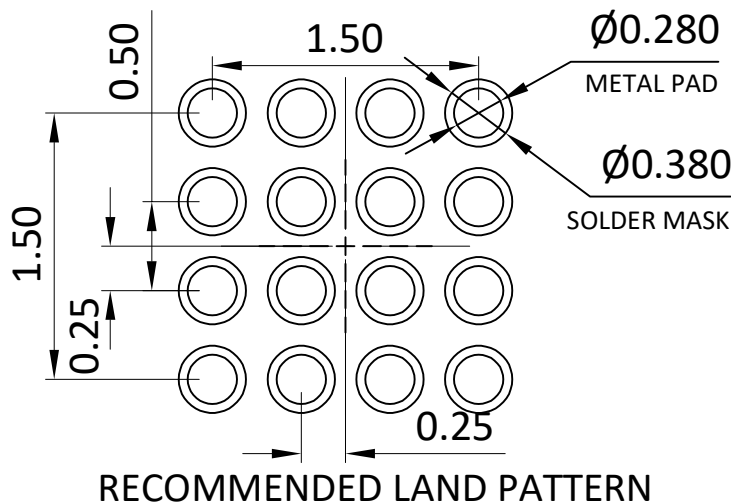
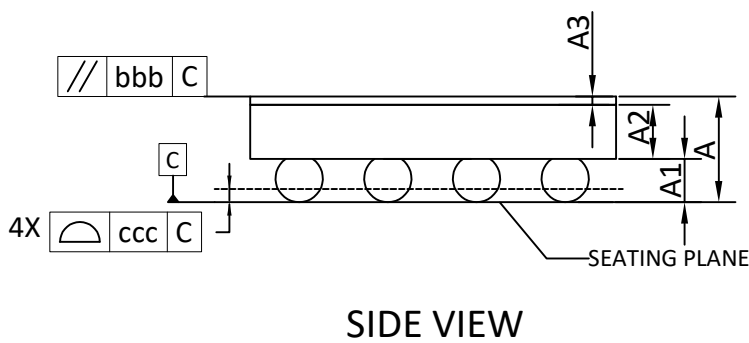
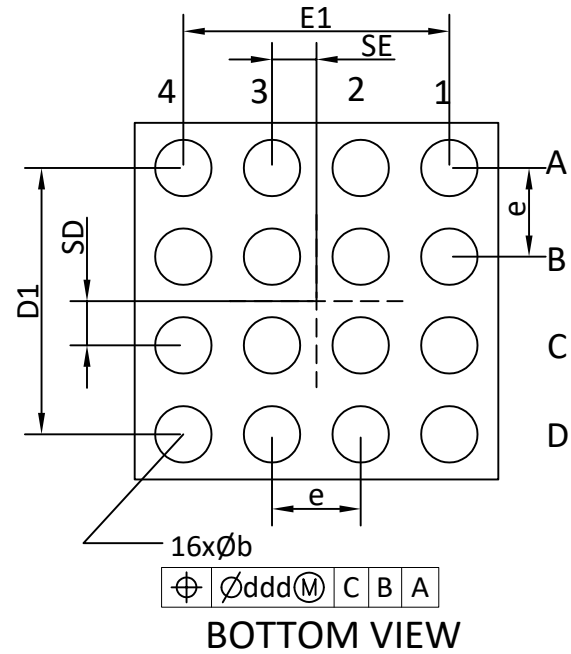
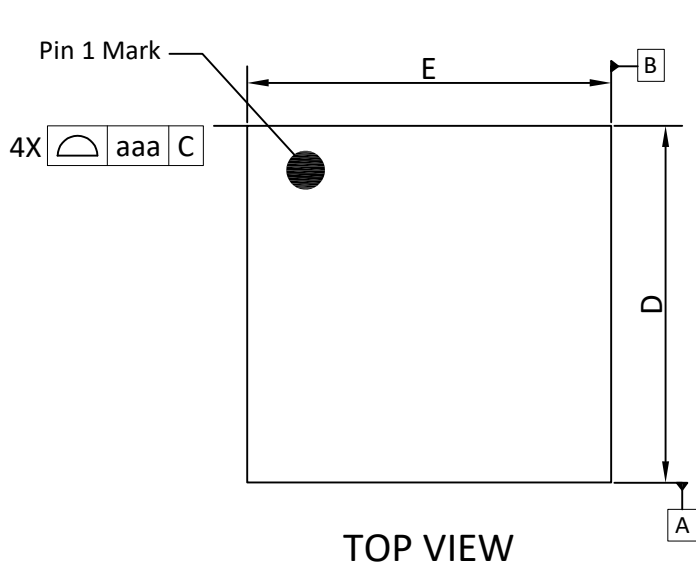

SYMBOL	DIMENSION IN MM			DIMENSION IN INCH		
	MIN.	NOM.	MAX.	MIN.	NOM.	MAX.
A	0.505	0.555	0.605	0.0199	0.0219	0.0238
A1	0.210	0.230	0.250	0.0083	0.0091	0.0098
A2	0.275	0.300	0.325	0.0108	0.0118	0.0128
A3	0.020	0.025	0.030	0.0008	0.0010	0.0012
D	1.985	2.010	2.035	0.0781	0.0791	0.0801
D1	1.450	1.500	1.550	0.0571	0.0591	0.0610
E	2.025	2.050	2.075	0.0797	0.0807	0.0817
E1	1.450	1.500	1.550	0.0571	0.0591	0.0610
b	0.290	0.320	0.350	0.0114	0.0126	0.0138
e	0.500 BSC.			0.0157 BSC.		
SD	0.250 BSC.			0.0079 BSC.		
SE	0.250 BSC.			0.0000 BSC.		
Tol. of Form&Position			Tol. of Form&Position			
aaa	0.05			0.0020		
bbb	0.05			0.0020		
ccc	0.05			0.0020		
ddd	0.05			0.0020		

### NOTES:

1. CONTROLLED DIMENSIONS ARE IN MILLIMETERS.
2. TOP VIEW IS THE VIEW OF TOP SURFACE OF THE PART HAVING INDEX AND PART NUMBER MARKING.