

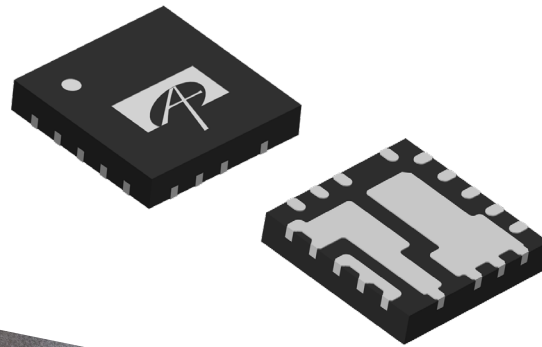

SMM, Smart Motor Module for BLDC Motor

AOS SMM products integrated half-bridge gate drivers with smart functions. The device includes one half-bridge gate driver, capable of driving internal high-side and low-side N-channel MOSFETs. Using two SMM products for single-phase motor drivers and three SMM products for three-phase motor drivers



PICs | SMM
for BLDC Motor



PICs | SMM, Smart Motor Module for BLDC Motor

Features

- Adjustable gate drive current control giving designers the ability to minimize EMI while maximizing power efficiency
- Self-powered Vcc
- 100% PWM duty operation
- Multiple advanced protections, SCP, OTP, Vcc UVLO and bootstrap UVLO
- Integrated 30V and 60V N-Channel MOSFETs by product

Applications

- BLDC Motor Drive
- Fans and Pumps
- Power Tools

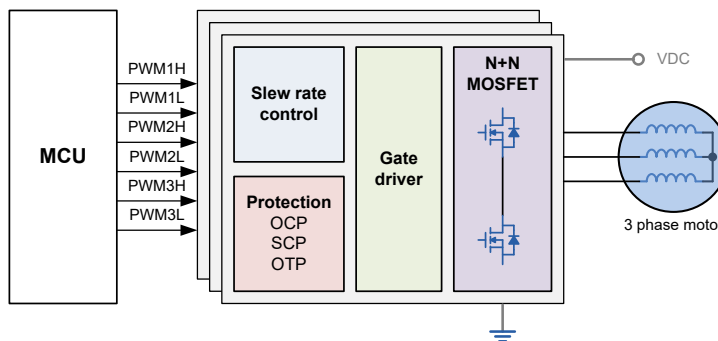

Part Number	Package	Min VIN (V)	Max VIN (V)	MOSFET R _{dson} (mΩ)	Max Output Current(A)	Internal LDO	100% HS duty	Temperature Monitor	Operating Temp.(°C)
AOZ9510QV	QFN4x4	10.8	28	6	20	Yes	Yes	Yes	-40 - 125
AOZ9511QV	QFN4x4	3.8	28	7.5	20	No	Yes	Yes	-40 - 125
AOZ9530QV	QFN3x3	10.8	28	11	7	Yes	Yes	No	-40 - 125
AOZ9551QV	QFN5x5	10.8	56	10	12	Yes	No	Yes	-40 - 125



AOS SALES OFFICES

UNITED STATES

475 Oakmead Pkwy
Sunnyvale, CA 94085
Phone: +1 (408) 830-9742
Email: Inquiries@aosmd.com

EUROPE

Phone: +49 7941 9039988
Email: AOSEurope@aosmd.com

JAPAN

16F Yurakucho Itocia
Office Tower
2-7-1 Yurakucho, Chiyoda-ku
Tokyo 100-0006
Phone: +81 (3) 6826-1401
Email: AOSJapan@aosmd.com

SOUTH KOREA

10th Floor, Bandi Building
Bongeunsa-ro 114
Gangnam-gu
Seoul 135-907
Phone: +82 (2) 557-8501
Email: AOSKorea@aosmd.com

TAIWAN

19F., No. 239, Sec. 2, Tiding Blvd.
Neihu District
Taipei City 114755
Phone: +886 (2) 8751-5616
Email: AOSTaiwan@aosmd.com

HONG KONG

Room 701, Tesbury Center
28 Queen's Road East
Wanchai
Phone: +86 (755) 8351-7733
Email: AOSChina@aosmd.com

CHINA

SHENZHEN

East 8/F, Matsunichi Building
#9996 Shennan Blvd.
Shenzhen 518057
Phone: +86 (755) 8351-7733
Email: AOSChina@aosmd.com

SHANGHAI

Room 602-603
Central Park Jing'an
329 Hengfeng Road
Jing'an District
Shanghai 200070
Phone: +86 (21) 6353-3218
Email: AOSChina@aosmd.com

To contact any of our sales partners worldwide, please visit our website at: www.aosmd.com/contact

Alpha and Omega Semiconductor Limited, or AOS, is a designer, developer and global supplier of a broad range of discrete power devices, wide band gap power devices, power management ICs and modules. AOS's products are aimed at, but not limited to applications such as portable computers, flat panel TVs, LED lighting, smart phones, battery packs, consumer and industrial motor controls, automotive electronics, and power supplies for TVs, computers, servers and telecommunication equipment.



Powering a Greener Future™