



ALPHA & OMEGA
SEMICONDUCTOR

AOS Semiconductor Product Reliability Report

AOZ18101DI rev A

Plastic Encapsulated Device

ALPHA & OMEGA Semiconductor, Inc

**475 Oakmead Parkway
Sunnyvale, CA 94085
United States**

**Tel: (408)830-9742
www.aosmd.com**

The AOS product reliability report summarizes the qualification results for AOZ18101DI in DFN3X3-10L package. Accelerated environmental tests are performed on a specific sample size, samples are electrically tested before and after each stress time point. Review of final electrical test results confirm that AOZ18101DI pass the AOS quality and reliability requirements. The released products will be categorized by its process family and routinely monitored for continuous improvement of product quality.

I. Reliability Stress Test Summary and Results

Test Item	Test Condition	Time Point	Sample Size / Lots	Number of Failures	Reference Standard
HTOL	$T_J = 125^{\circ}\text{C}$, $V_{IN} = 20\text{V}$	168 / 500 / 1000 hours	231 pcs (3 lots)	0	JESD22-A108
Preconditioning (Note A)	$T_A = 85^{\circ}\text{C}$, RH = 85% + 3 cycle reflow @ 260°C (MSL 3)	168hours	924 pcs (3 lots)	0	JESD22-A113
HAST	$T_A = 130^{\circ}\text{C}$, RH = 85%, P = 33.3psia, $V_{IN} = 20\text{V}$	96 hours	231 pcs (3 lots)	0	JESD22-A110
Temperature Cycle	$T_A = -65^{\circ}\text{C}$ to 150°C , air to air	500 / 1000 cycles	231 pcs (3 lots)	0	JESD22-A104
HTSL	$T_A = 150^{\circ}\text{C}$	1000 hours	231 pcs (3 lots)	0	JESD22-A103
Autoclave	$T_A = 121^{\circ}\text{C}$, RH = 100%, P = 29.7psia	96 hours	231 pcs	0	JESD22-A102
HTGB (MOSFET)	$T_J = 150^{\circ}\text{C}$, $V_{GS} = 12\text{V}$	168 / 500 hours	231 (3 lots)	0	JESD22-A108
HTRB (MOSFET)	$T_J = 150^{\circ}\text{C}$, $V_{DS} = 30\text{V}$	168 / 500 hours	231 (3 lots)	0	JESD22-A108

Note: The reliability data presents total of available generic data up to the published date.
 Note A: MSL (Moisture Sensitivity Level) 3 based on J-STD-020

II. Reliability Evaluation

The presentation of FIT rate for the individual product reliability is restricted by the actual burn-in sample size of the product technology. Failure Rate Determination is based on JEDEC Standard JESD 85.

FIT rate (failures per billion device hours): 0.396

MTTF = 2713.4 million hrs

Condition: $V_o = 14V$, $T_o = 55^\circ C$, $V_{s(IC)} = 20V$, $V_{s(MOSFET)} = 30V$, $T_{s(IC)} = 140^\circ C$ and $T_{s(MOSFET)} = 150^\circ C$

Sample Size: MOSFET = 6,153, IC = 640

The failure rate (λ) is calculated as follows:

$$\lambda = \chi^2[CL, (2f+2)] / 2 \times [1/(SS \times t \times AF)]; \text{ [equation 1]} \quad \text{where} \quad \begin{array}{l} CL = \% \text{ of confidence level} \\ f = \text{number of failure} \\ SS = \text{sample size} \\ t = \text{stress time} \end{array}$$

Looking up the $\chi^2/2$ table for zero failure (burn-in) with 60% confidence, the value of $\chi^2[CL, (2f+2)] / 2$ is 0.92.

The Acceleration Factor (AF) is calculated from the following formula (both temperature and voltage acceleration factors are used in the final acceleration factor calculation) :

$$AF = AF_T \times AF_V = \exp[(E_a/k) \times (1/T_o - 1/T_s)] \times \exp[\beta (V_s - V_o)] \quad \text{where} \quad \begin{array}{l} E_a = \text{activation energy} \\ k = \text{Boltzmann constant} \\ T_o = \text{operating } T_J \\ T_s = \text{stress } T_J \\ V_s = \text{stress voltage} \\ V_o = \text{operating voltage} \\ \beta = \text{voltage acceleration coefficient} \end{array}$$

Assuming typical operating environment, $V_o = 14V$, $T_o = 55^\circ C$, $E_a = 0.7eV$, $V_{s(IC)} = 20V$, $V_{s(MOSFET)} = 30V$, $T_{s(IC)} = 125^\circ C$ and $T_{s(MOSFET)} = 150^\circ C$, $\beta = 0.5$ (silicon defect)

$$AF(DriverIC) = \exp \left[\left(\frac{0.7}{8.617E - 5} \right) \cdot \left(\frac{1}{273 + 55} - \frac{1}{273 + 140} \right) \right] \cdot \exp[0.5 \cdot (20V - 14V)]$$

$$AF(MOSFET) = \exp \left[\left(\frac{0.7}{8.617E - 5} \right) \cdot \left(\frac{1}{273 + 55} - \frac{1}{273 + 150} \right) \right] \cdot \exp[0.5 \cdot (30V - 14V)]$$

Substituting the values in equation 1, we have $\lambda = 2 \cdot \lambda(MOSFET) + \lambda(DriverIC) =$

$$0.92 \cdot \frac{1}{\text{Sample Size} \cdot \text{Stress Duration} \cdot AF(MOSFET)} + \frac{1}{\text{sample Size} \cdot \text{Stress Duration} \cdot AF(DriverIC)} \text{ hr}^{-1}$$

$\lambda = 0.369 \cdot 10^{-9} \text{ hr}^{-1}$ or 0.369 FIT; $MTTF = (1/\lambda) = 2713.4 \text{ million hrs} = 309,745 \text{ years}$

The calculation shows failure rate is 0.369 FIT, MTTF is 2713.4 million hours under typical operating conditions.

III. ESD and Latch Up Test Results

Test	Test Conditions	Total Sample Size	Number of Failures	Reference Standard
Electrostatic Discharge Human Body Model	T _A = 25°C, +/-4kV	10	0	JESD-A114
Electrostatic Discharge Charged Device Model	T _A = 25°C, +/-1kV	10	0	JESD-C101
Latch Up	T _A = 25°C, +/-200mA, 1.27x OV	10	0	JESD78
Latch Up	T _A = 125°C, +/-200mA, 1.27x OV	10	0	JESD78

Note: ATE results are used to determine PASS/FAIL. Parametric shift<10%.

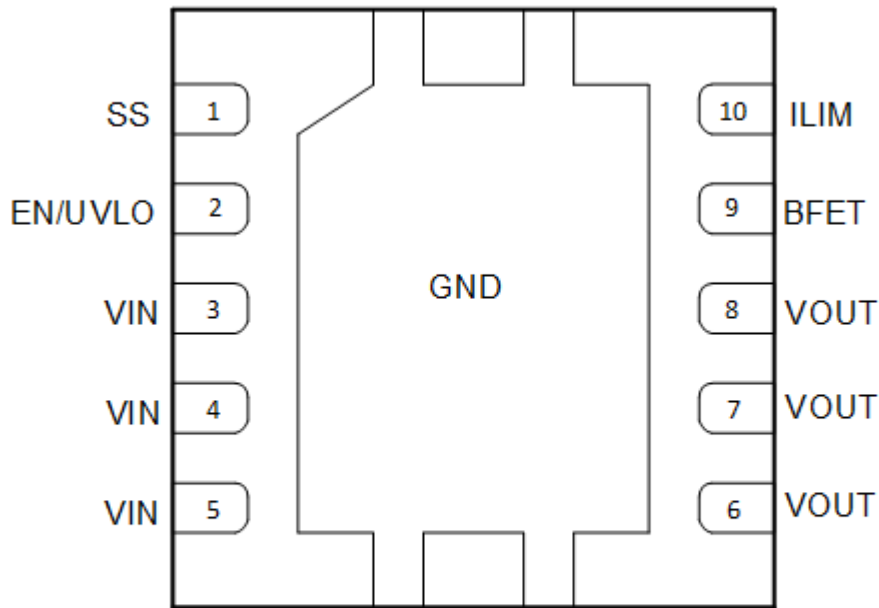

DFN3x3-10L
 (Top Transparent View)